



INFINITY

Серия INFINITY

 90000 Стр. 14 - 15	Новинка  90010 90011 Стр. 16	Новинка  90012 Стр. 16	 90013 90014 Стр. 17	 90015 90018 Стр. 17 - 18	 90017 Стр. 17	 90019 Стр. 18	Новинка  90020 Стр. 19	 90030 Стр. 19
 90040 Стр. 20	 90130 Стр. 20 - 21	 90140 Стр. 21	 90150 Стр. 21	 90160 Стр. 22	 90230 Стр. 22	 90235 Стр. 23	 90236 90237 Стр. 23 - 24	 90240 Стр. 25
 90246 Стр. 25	 90247 90248 Стр. 25 - 26	 90241 Стр. 27	 90242 Стр. 27	 90249 Стр. 27	 90252 Стр. 29	 90253 Стр. 29	 90610 Стр. 30	 90620 Стр. 30
 90625 90626 Стр. 31	 90627 Стр. 31	 90628 Стр. 32	 90630 90631 Стр. 32	 90642 90643 Стр. 33	 90644 90645 Стр. 34	 90600 90601 Стр. 35	 90602 90603 Стр. 35 - 36	 90660 90661 Стр. 36
 90662 90663 Стр. 37	 90664 90665 Стр. 37 - 38	 90700 Стр. 38	 90705 Стр. 39	 90710 Стр. 39	 90720 90721 Стр. 39 - 40	 90725 90726 Стр. 40	Новинка  90740 Стр. 41	 90790 Стр. 43
Новинка  90806 Стр. 44	Новинка  90808 Стр. 44	 90815 Стр. 44	 90817 Стр. 45	 90820 Стр. 45	 90825 Стр. 46	 90826 Стр. 47	 90830 Стр. 48	 90860 90861 Стр. 48
 90870 Стр. 48	 90880 Стр. 49	 90885 Стр. 49	 VAL01 VAL03 Стр. 49	 90889 Стр. 50	 90250 90251 Стр. 51 - 52	Новинка  90259 Стр. 53	Новинка  90260 Стр. 53	 90986 Стр. 53
 90975 Стр. 54	 Принадлежности Стр. 59 - 66							

ТРУБОПРОВОДЫ СЖАТОГО ВОЗДУХА, ИНЕРТНЫХ ГАЗОВ И ВАКУУМА
DISTRIBUTION SYSTEM FOR COMPRESSED AIR, INERT GASES AND VACUUM
DRUCKLUFTVERTEILUNGSSYSTEM, EDELGASE UND VAKUUM
RÉSEAU DE DISTRIBUTION POUR AIR COMPRIMÉ, GAZ NEUTRES ET VIDE
INDUSTRIEL LÍNEA DE DISTRIBUCIÓN DE AIRE COMPRIMIDO, GASES INERTES Y
VACÍO LINHA DE DISTRIBUIÇÃO DE AR COMPRIMIDO, GÁS E VÁCUO



INFINITY LINE



RU

Основные преимущества

- Система отделения конденсата
- Простота и скорость монтажа
- Высокая надежность и безопасность
- Высокая пропускная способность
- Широкий спектр принадлежностей
- Огнестойкость: система не воспламеняется и не поддерживает горение
- Сборка магистральных трубопроводов на втычных фитингах
- Цельнометаллическая система

GB

Main advantages

- Separation system for the condensate
- Easiness and quickness of assembling
- Reliability and security
- High flow rate
- Wide range of accessories
- Fire resistance: The system does not stroke or propagate any fires
- Push-in fittings for installation of compressed-air pipelines
- Totally metallic system

DE

Hauptvorteile

- System mit abscheidung des kondensats
- Leichte und schnelle montage
- Zuverlässig und sicher
- Umfangreiches zubehör
- Hoher luftdurchlass
- Feuerbeständigkeit: alle komponenten sind flammwidrig ohne flammausbreitung
- Steckverschraubungen für die installation von druckluft-verteilsystemen
- System total metallisch

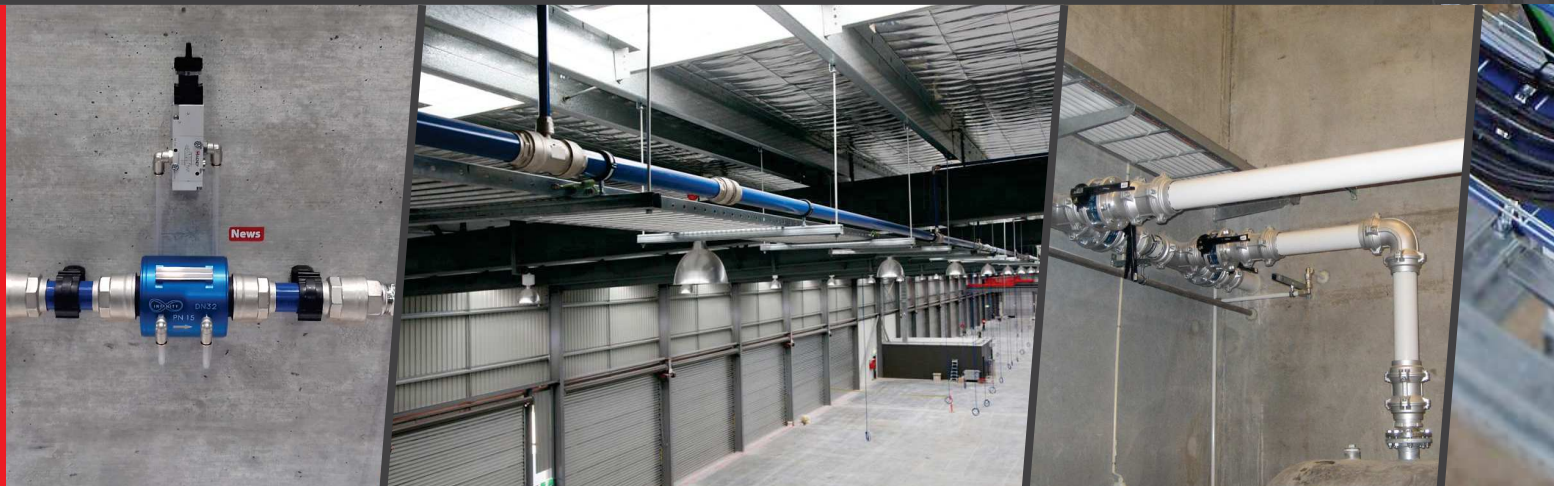

FR

Principaux avantages

- Système de retenue des condensats
- Facile et rapide à installer
- Fiable et sûre
- Large gamme d'accessoires
- Haut débit
- Tenue au feu: le système ne propage pas de fumée ou de flamme
- Raccords instantanés pour réseaux primaires
- Système totalement métallique

ES

Principales ventajas

- Sistema de separación de condensados
- Fácilidad y rapidez de montaje
- Fiabilidad y seguridad
- Elevado caudal de aire
- Resistencia al fuego: el sistema no alimenta ni propaga el fuego
- Racor automático para la distribución del aire comprimido
- Sistema totalmente metálico

PT

Principais vantagens

- Sistema de separação de condensado
- Facilidade e rapidez de montagem
- Confiabilidade e segurança
- Alta capacidade de vazão de ar
- Gama completa de acessórios
- Resistência as fogo: o sistema não alimenta e não propaga o fogo
- Conexões automáticas para a instalação de redes de ar comprimido
- Sistema totalmente metálico



AIGNEP

Excellent solutions in Fluidtechnology

www.aignep.com



ТЕХНИЧЕСКИЕ ХАРАКТЕРИСТИКИ

TECHNICAL CHARACTERISTICS
 TECHNISCHE ANGABEN
 CARACTÉRISTIQUES TECHNIQUES
 CARACTERÍSTICAS TÉCNICAS
 CARACTERÍSTICAS TÉCNICAS

**ВТЫЧНАЯ СХЕМА PUSH-IN
 Ø 20 - 25 - 32 - 40 - 50 - 63 мм**

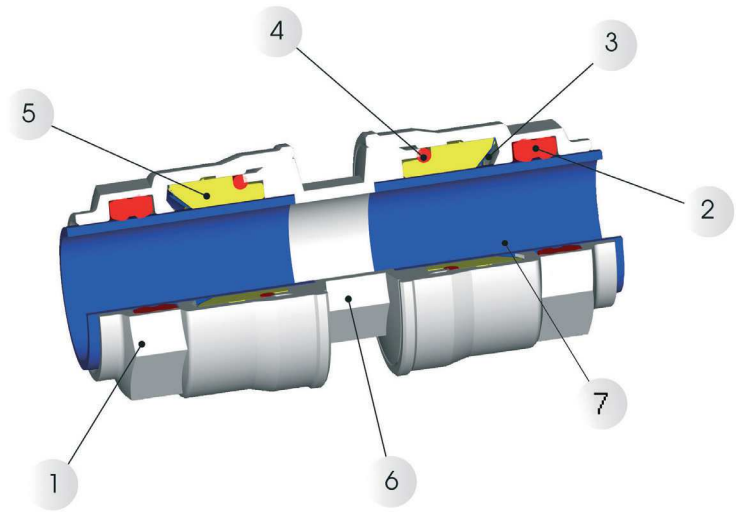

Нормативная документация

Reference standard
 Entspricht der Norm
 Norme de référence
 Normativa de referencia
 Norma de referência

1907/2006 REACH ✓	2011/65/CE RoHS ✓
PED 2014/68/UE	SILICON FREE

Материалы и компоненты

RU

- 1 Гайка латунная никелированная (алюминий Ø63)
- 2 Уплотнение из NBR
- 3 Зажимная шайба из нерж стали AISI 304
- 4 Уплотнительное кольцо из NBR
- 5 Кольцо фиксации из технополимера
- 6 Корпус латунный никелированный (алюминий Ø63)
- 7 Труба алюминиевая экструдированная, порошковая окраска

Component Parts and Materials

GB

- 1 Nut made in nickel-plated brass (aluminum Ø63)
- 2 Seal made in nbr
- 3 Clamping washer made in INOX AISI 304
- 4 O-ring seals made in NBR
- 5 Safety ring made in technopolymer
- 6 Body made in nickel-plated brass (aluminum Ø63)
- 7 Extruded aluminium tube calibrated and powder coated

Komponenten und Materialien

DE

- 1 Mutter Messing vernickelt (Aluminium Ø63)
- 2 Formdichtung NBR
- 3 Zahnscheibe Edelstahl AISI 304
- 4 O-Ring Dichtung NBR
- 5 Sicherheitsring Technopolymer
- 6 Körper Messing vernickelt (Aluminium Ø63)
- 7 Rohr Aluminium extrudiert, kalibriert und lackiert

Matériaux et Composants

FR

- 1 Ecrou: laiton nickelé (aluminium Ø63)
- 2 Joint de forme: NBR
- 3 Rondelle d'accrochage: INOX AISI 304
- 4 Joint torique: NBR
- 5 Rondelle de sécurité: technopolymère
- 6 Corps: laiton nickelé (aluminium Ø63)
- 7 Tube: aluminium extrudé, calibré et laqué

Materiales y Componentes

ES

- 1 Tuerca en latón niquelado (aluminio Ø63)
- 2 Junta en NBR
- 3 Pinza de sujeción en INOX AISI 304
- 4 Junta tórica en NBR
- 5 Anillo de seguridad en tecnopolímero
- 6 Cuerpo en latón niquelado (aluminio Ø63)
- 7 Tubo en aluminio extrusionado calibrado y pintado

Materiais e Componentes

PT

- 1 Porca em Latão Niquelado (aluminio Ø63)
- 2 Guarnições em NBR
- 3 Pinças de travamento em INOX AISI 304
- 4 Guarnições O-RING em NBR
- 5 Anel de Segurança em Tecnopolímero
- 6 Corpo em Latão Niquelado
- 7 Tubo em alumínio extrudado, calibrado e com pintura a pó



Давление

Pressures
 Druckbereich
 Pressions
 Presiones
 Pressões

- 0.99 бар (-0.099 МПа)
16 бар (1.6 МПа)



Температура

Temperatures
 Temperatur
 Températures
 Temperaturas
 Temperaturas

- 20 °C
+ 80 °C



Совместимые среды

Воздух / Вакуум / Инертные газы (АЗОТ-АРГОН)

Fluids
 Compressed air / Vacuum / Inert gas (NITROGEN-ARGON)

Geeignete Medien
 Druckluft / Vakuum / Inertgase (STICKSTOFF, ARGON)

Fluides compatibles
 Air comprimé / Vide / Gaz neutres (AZOTE, ARGON)

Fluidos compatibles
 Aire comprimido / Vacío / Gases inertes (NITRÓGENO, ARGÓN)

Fluidos compatíveis
 Ar comprimido / Vácuo / Gases inertes (NITROGÊNIO, ARGÔNIO)



Резьбы

RU

Наружная коническая резьба по ISO 7.
 Внутренняя резьба цилиндрическая ISO 228.

Threads

GB

Male threads taper in conformity with ISO 7.
 Female threads in conformity with ISO 228.

Gewindearten

DE

Aussengewinde konisch nach Norm ISO 7.
 Innengewinde zylindrisch nach Norm ISO 228.

Filetages

FR

Filetage mâle conforme à la norme ISO 7.
 Filetage femelle conforme à la norme ISO 228.

Roscas

ES

Macho: Gas cónica ISO 7.
 Hembra: Gas cilíndrica ISO 228.

Roscas

PT

Machos gás cónico conforme ISO 7.
 Fêmeas gás paralela conforme ISO 228.

Технические характеристики труб
 Technical characteristics to the tubes
 Technische Angaben der Rohre
 Spécifications techniques des tubes
 Características técnicas del tubo
 Características técnicas dos tubos

Экструдированный алюминий
 Extruded aluminium
 Aluminium extrudiert
 Aluminium extrudé
 Aluminio extrusionado
 Alumínio extrudado

UNI 9006/1 Al Mg 0.5
 Si 0.4 Fe 0.2

Обозначение по UNI EN 573-3
 Designations UNI EN 573-3
 Bezeichnung UNI EN 573-3
 Désignation UNI EN 573-3
 Designación UNI EN 573-3
 Designação UNI EN 573-3

EN AW 6060 T6

Технические характеристики труб
 Technical characteristics to the tubes
 Technische Angaben der Rohre
 Spécifications techniques des tubes
 Características técnicas del tubo
 Características técnicas dos tubos

Покрытие поверхности
 Surface treatment
 Spezifisches Gewicht
 Traitement de surface
 Tratamiento superficial
 Tratamento superficial

Порошковое электростатическое
 Electrostatic painting
 Elektrostatische Lackierung
 Peinture électrostatique
 Pintura electroestática
 Pintura eletrostática

Удельный вес
 Specific weight
 Spezifisches Gewicht
 Poids spécifique
 Peso específico
 Peso específico

2.70 кг/дм³

Технические характеристики труб
 Technical characteristics to the tubes
 Technische Angaben der Rohre
 Spécifications techniques des tubes
 Características técnicas del tubo
 Características técnicas dos tubos

Коэффициент расширения
 Expansion coefficient
 Ausdehnungskoeffizient
 Coefficient de dilatation
 Coeficiente de dilatación
 Coeficiente de dilatação

0.024 мм/(м °C)



Монтаж Ø 20-25-32-40

IT

- 1 Фитинги Ø20 - Ø25 - Ø32 - Ø40 предварительно собраны. Трубы штангами 4 и 6 м с покрытием, калибровкой, без заусенцев.
- 2 Задвиньте трубу в фитинг для автоматической фиксации.
- 3 Для повторной сборки фитинга после разъединения применяйте крутящие моменты, указанные в таблице.

Assembling Ø 20-25-32-40

GB

- 1 Fittings of Ø20 - Ø25 - Ø32 - Ø40 are pre-assembled. Tubes of 4 & 6 m are pre-coated, calibrated and burred.
- 2 Push tube into the fitting for automatic connection.
- 3 In case of fitting disassembly, use the torques as in the chart to re-assemble the fitting.

Montageanleitung Ø 20-25-32-40

DE

- 1 Die Verschraubungen Ø20 - Ø25 - Ø32 - Ø40 sind mit der Mutter vormontiert. Die Rohre von 4 und 6 m sind lackiert, kalibriert und entgratet.
- 2 Um das Rohr anzuschliessen, drücken Sie es bis zum Anschlag in den Anschluss. Fertig!
- 3 Im Fall von demontierten Muttern benutzen Sie bitte folgende Drehmomente um den Anschluss wieder zusammenzusetzen.

Assemblage Ø 20-25-32-40

FR

- 1 Les raccords de Ø20 - Ø25 - Ø32 - Ø40 mm sont livrés assemblés et prêts à l'emploi. Les tubes de 4 & 6 m sont laqués, calibrés et chanfreinés.
- 2 Pour connecter le tube, il suffit de l'enfoncer dans le raccord jusqu'à la butée.
- 3 En cas de démontage/montage des écrous, veuillez utiliser les couples de serrage suivants pour ré-assembler les raccords.

Montaje Ø 20-25-32-40

ES

- 1 Los racores de Ø20 - Ø25 - Ø32 - Ø40 vienen premontados con la tuerca totalmente apretada. Los tubos de 4 mts. vienen barnizados, calibrados y desbarbados.
- 2 Introducir el tubo hasta el fondo del racor para la conexión automática.
- 3 En caso de necesitar desmontar el racor, considerar los valores de esfuerzo de torsión que se especifican en la siguiente tabla para su posterior montaje.

Montagem Ø 20-25-32-40

PT

- 1 As conexões Ø20 - Ø25 - Ø32 - Ø40 são pré-montadas com porca já fechada. Os tubos de 4 e 6 m são já pintados, calibrados e desbastados.
- 2 Inserir o tubo até o final da conexão para executar a montagem e garantir a conexão automática.
- 3 No caso de desmontagem da conexão, utilize os torques informados na tabela para efetuar a remontagem.

1



2



3

Ø мм	Требуемые моменты - Torque specifications Angaben Drehmoment - Couple de serrage Par de apriete - Torque
20	3 Нм
25	3 Нм
32	4 Нм
40	6.5 Нм

Монтаж Ø 50 - 63

IT

- 1 Фитинги Ø50 - Ø63 предварительно собраны, с незатянутой гайкой для облегченного ввода трубы. Трубы в штангах 4 и 6 м, с покрытием, калибровкой, без заусенцев.
- 2 Вставьте трубу в фитинг и затяните гайку в соответствии с моментами, указанными в таблице.

Assembling Ø 50 - 63

GB

- 1 Fittings of Ø50 - Ø63 are pre-assembled with nut untwisted to help tube connection. Tubes of 4 & 6 m are pre-coated, calibrated and burred.
- 2 Push tube into the fitting for connection and tighten the nut using torques as in the chart.

Montageanleitung Ø 50 - 63

DE

- 1 Die Verschraubungen Ø50 - Ø63 sind mit der Mutter nicht vormontiert, um das Einführen des Rohres in den Anschluss zu erleichtern. Die Rohre von 4 und 6 m sind lackiert, kalibriert und entgratet.
- 2 Zum Verbinden schieben Sie das Rohr bis zum Anschlag in den Anschluss und ziehen die Mutter mit dem in der Tabelle angegebenen Drehmoment an.

Assemblage Ø 50 - 63

FR

- 1 Afin de faciliter l'introduction du tube dans le raccord, les écrous de Ø50 mm et Ø63 mm sont pré-assemblés sans tension avec le raccord. Les tubes de 4 & 6 m sont laqués, calibrés et chanfreinés.
- 2 Enfoncer le tube dans le raccord jusqu'à la butée puis serrer l'écrou au couple mentionné dans le tableau suivant, pour le connecter.

Montaje Ø 50 - 63

ES

- 1 Los racores Ø50 - Ø63 vienen premontados con la tuerca sobre el racor aunque sin apretar para facilitar la inserción del tubo. Los tubos de 4 mts. vienen barnizados, calibrados y desbarbados.
- 2 Introducir el tubo hasta el fondo del racor para la conexión y apretar la tuerca utilizando los valores de esfuerzo de torsión que se especifican en la siguiente tabla.

Montagem Ø 50 - 63

PT

- 1 As conexões Ø50 - Ø63 são pré-montadas com porca solta para facilitar a inserção do tubo. Os tubos de 4 e 6 m são já pintados, calibrados e desbastados.
- 2 Inserir o tubo até o final da conexão para efetuar a montagem e apertar a porca utilizando os torques informados na tabela.

1



2

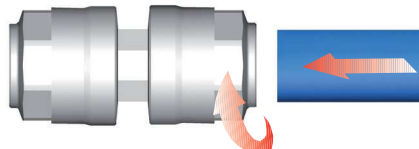

Ø мм	Требуемые моменты - Torque specifications Angaben Drehmoment - Couple de serrage Par de apriete - Torque
50	75 Нм
63	85 Нм



ТЕХНИЧЕСКИЕ ХАРАКТЕРИСТИКИ

TECHNICAL CHARACTERISTICS
TECHNISCHE ANGABEN
CARACTÉRISTIQUES TECHNIQUES
CARACTERÍSTICAS TÉCNICAS
CARACTERÍSTICAS TÉCNICAS

Ø 80 - 110 мм

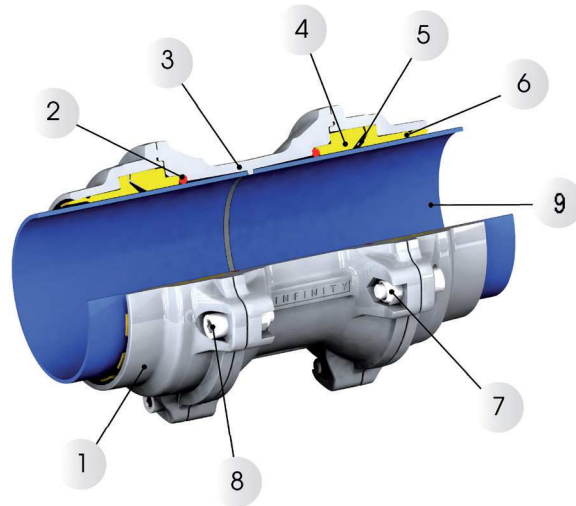

Нормативная документация

Reference standard
Entspricht der Norm
Norme de référence
Normativa de referencia
Norma de referência

1907/2006 REACH ✓	2011/65/CE RoHS ✓
PED 2014/68/UE	SILICON FREE

Материалы и компоненты

IT

- 1 Гайка алюминиевая, с обработкой поверхности
- 2 Уплотнительные кольца из NBR
- 3 Корпус алюминиевый, с обработкой поверхности
- 4 Кольцо фиксации из технополимера
- 5 Зажимное кольцо из нержавеющей стали AISI 301
- 6 Направляющее кольцо из технополимера
- 7 Самоконтрающаяся гайка из оцинкованной стали
- 8 Винт TCEI из оцинкованной стали
- 9 Труба из алюминия, экструдированная, калиброванная, с покрытием

Component Parts and Materials

GB

- 1 Nut made in aluminium with finished surface treatment
- 2 O-RING Seal made in NBR
- 3 Body made in aluminium with finished surface treatment
- 4 Safety Ring made in Technopolymeric
- 5 Clamping Washer made in AISI 301
- 6 Tube-guide Ring made in technopolymeric
- 7 Selflocking Nut in Zinc-Plated Steel
- 8 TCEI Screw in Zinc-Plated Steel
- 9 Extruded Alluminium tube calibrated and powder coated

Komponenten und Materialien

DE

- 1 Mutter Aluminium Oberflächenbehandelt
- 2 O-Ring Dichtung NBR
- 3 Körper Aluminium Oberflächenbehandelt
- 4 Sicherheitsring Technopolymer
- 5 Zahnscheibe Edelstahl AISI 301
- 6 Rohrführungsring Technopolymer
- 7 Selbstsichernde Mutter Stahl verzinkt
- 8 Schraube TCEI Stahl verzinkt
- 9 Rohr Aluminium extrudiert, kalibriert und lackiert

Matériaux et Composants

FR

- 1 Ecrou: aluminium traité
- 2 Joint torique: NBR
- 3 Corps: aluminium traité
- 4 Rondelle de sécurité: technopolymère
- 5 Pince d'accrochage: INOX AISI 301
- 6 Guidage pour tube: technopolymère
- 7 Ecrou autobloquant: acier zingué
- 8 Vis TCEI: acier zingué
- 9 Tube: aluminium extrudé, calibré et laqué

Materiales y Componentes

ES

- 1 Tuerca en aluminio tratado superficialmente
- 2 Junta tórica en NBR
- 3 Cuerpo en aluminio tratado superficialmente
- 4 Anillo de seguridad en tecnopolímero
- 5 Pinza de sujeción en INOX AISI 301
- 6 Anillo guía-tubo en tecnopolímero
- 7 Tuerca autoblocante en acero zincado
- 8 Tornillo TCEI en acero zincado
- 9 Tubo en aluminio extrusionado calibrado y pintado

Materiais e Componentes

PT

- 1 Porca em alumínio com tratamento superficial
- 2 Guarnição O-RING em NBR
- 3 Corpo em alumínio com tratamento superficial
- 4 Anel de segurança em Tecnopolímero
- 5 Pinças de travamento em INOX AISI 301
- 6 Anel guia-tubo em Tecnopolímero
- 7 Porta auto-travante em aço zincado
- 8 Parafusos TCEI em aço zincado
- 9 Tubo em alumínio extrudado, calibrado e com pintura a pó



Давление

Pressures
Druckbereich
Pressions
Presiones
Pressões

- 0.99 bar (-0.099 MPa)
16 bar (1.6 MPa)



Температура

Temperatures
Temperatur
Températures
Temperaturas
Temperaturas

- 20 °C
+ 80 °C



Совместимые среды

Воздух / Вакуум / Инертные газы (АЗОТ-АРГОН)

Fluids
Compressed air / Vacuum / Inert gas (NITROGEN-ARGON)

Geeignete Medien
Druckluft / Vakuum / Inertgase (STICKSTOFF, ARGON)

Fluides compatibles
Air comprimé / Vide / Gaz neutres (AZOTE, ARGON)

Fluidos compatibles
Aire comprimido / Vacuo / Gases inertes (NITRÓGENO, ARGÓN)

Fluidos compatíveis
Ar comprimido / Vácuo / Gases inertes (NITRÓGENIO, ARGÓNIO)



Соединения

RU

Фланцевые (UNI EN 1092 - 4 PN 16) (ANSI 150-LB).
Резьбы внутренние цилиндрические по ISO 228.

Threads

GB

Flanged Tube (UNI EN 1092 - 4 PN 16) (ANSI 150-LB).
Female threads in conformity with ISO 228.

Gewindearten

DE

Kupplungsflansch (UNI EN 1092 - 4 PN 16) (ANSI 150-LB).
Innengewinde zylindrisch nach Norm ISO 228.

Filetages

FR

Raccord flasque (UNI EN 1092 - 4 PN 16) (ANSI 150-LB).
Filetage femelle conforme à la norme ISO 228.

Roscas

ES

Racor con brida (UNI EN 1092 - 4 PN 16) (ANSI 150-LB).
Hembra gas cilíndrica ISO 228.

Roscas

PT

Conexão flangeada (UNI EN 1092 - 4 PN 16) (ANSI 150-LB).
Fêmea gás paralela ISO 228.



Технические характеристики труб

Technical characteristics to the tubes
 Technische Angaben der Rohre
 Spécifications techniques des tubes
 Características técnicas del tubo
 Características técnicas dos tubos

Экструдированный алюминий
 Extruded aluminium
 Aluminium extrudiert
 Aluminium extrudé
 Aluminio extrusionado
 Aluminio extrudado

UNI 9006/1 Al Mg 0.5
 Si 0.4 Fe 0.2

Обозначение по UNI EN 573-3
 Designations UNI EN 573-3
 Bezeichnung UNI EN 573-3
 Désignation UNI EN 573-3
 Designación UNI EN 573-3
 Designação UNI EN 573-3

EN AW 6060 T6

Технические характеристики труб

Technical characteristics to the tubes
 Technische Angaben der Rohre
 Spécifications techniques des tubes
 Características técnicas del tubo
 Características técnicas dos tubos

Покрытие поверхности
 Surface treatment
 Spezifisches Gewicht
 Traitement de surface
 Tratamiento superficial
 Tratamiento superficial

Порошковое электростатическое
 Electrostatic painting
 Elektrostatische Lackierung
 Peinture électrostatique
 Pintura electrostática
 Pintura eletroestática

Удельный вес
 Specific weight
 Spezifisches Gewicht
 Poids spécifique
 Peso específico
 Peso específico

2,70 кг/дм³

Технические характеристики труб

Technical characteristics to the tubes
 Technische Angaben der Rohre
 Spécifications techniques des tubes
 Características técnicas del tubo
 Características técnicas dos tubos

Коэффициент расширения
 Expansion coefficient
 Ausdehnungskoeffizient
 Coefficient de dilatation
 Coeficiente de dilatación
 Coeficiente de dilatação

0,024 мм/(м °C)



Монтаж Ø 80 - 110

RU

- 1 Фитинги Ø80 и Ø110 предварительно собраны, с незатянутыми четырьмя винтами для облегчения ввода конца трубы. Трубы в стангах 4 и 6 м с покрытием, калиброванные, беззаусенцев.
- 2 Введите конец трубы в фитинг до упора и заверните крепежные винты в соответствии с предлагаемой схемой. Момент затяга 30 Нм.

Assembling Ø 80 - 110

GB

- 1 Fittings of Ø80 e Ø110 are pre-assembled with four screws untwisted to help tube connection. Tubes of 4 & 6 mt are pre-coated, calibrated and burred.
- 2 Push tube into the fitting for automatic connection and screw up in the suggested sequence. Tightening torque 30Nm.

Montageanleitung Ø 80 - 110

DE

- 1 Die Verschraubungen Ø80 und Ø110 sind mit vier nicht angezogenen Schrauben vormontiert, um das Einsetzen des Rohres zu erleichtern. Die Rohre von 4 und 6 m sind lackiert, kalibriert und entgratet.
- 2 Zum Verbinden schieben Sie das Rohr bis zum Anschlag in den Anschluss und ziehen die vier Schrauben mit einem Drehmoment von 30 Nm gemäss der Abbildung an.

Assemblage Ø 80 - 110

FR

- 1 Afin de faciliter l'introduction du tube dans le raccord, les flasques de Ø80 et Ø110 mm sont pré-assemblés sans tension avec le raccord. Les tubes de 4 & 6 m sont laqués, calibrés et chanfreinés.
- 2 Enfoncer le tube dans le raccord jusqu'à la butée puis serrer les vis à un couple de 30 Nm selon le schéma ci-dessous pour le connecter.

Montaje Ø 80 - 110

ES

- 1 Los racores de Ø110 vienen premontados con cuatro tornillos para facilitar la inserción del tubo. Los tubos de 4 mts. vienen barnizados, calibrados y desbarbados.
- 2 Introducir el tubo hasta el fondo del racor para la conexión y apretar los cuatro tornillos en el orden sugerido. Esfuerzo de torsión 30Nm.

Montagem Ø 80 - 110

PT

- 1 As conexões Ø80 - Ø110 são pré-montadas com quatro parafusos soltos para facilitar a inserção do tubo. Os tubos de 4 e 6 mt são já pintados, calibrados e desbastados.
- 2 Inserir o tubo até o final da conexão para efetuar a montagem e apertar os quatro parafusos na sequência sugerida. Torque de aperto 30Nm.

1

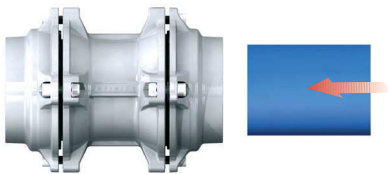

2

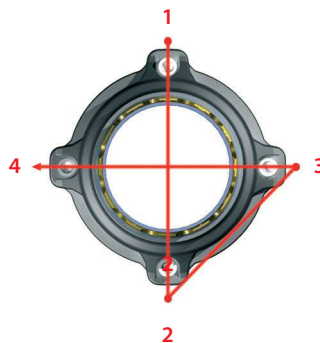

Ø мм	Требуемые моменты - Torque specifications Angaben Drehmoment - Couple de serrage Par de apriete - Torque
80	30 Нм
110	30 Нм



<p>Соединение труб IT</p> <p>Правильная глубина ввода конца трубы отмечена символом стрелки. При необходимости обрезки трубы в размер рекомендуется нанести соответствующую маркировку на обрезанный конец.</p>	<p>Tube Connection GB</p> <p>The correct connection of tube is confirmed by the position of the arrow pre-stamp. If you need to cut the tube, mark the distance of tube to insert in the fitting.</p>	<p>Einstecktiefe des Rohres DE</p> <p>Die korrekte Einstecktiefe des Rohres in den Anschluss wird durch den vormarkierten Pfeil angegeben. Wenn das Rohr geschnitten werden muss, wird empfohlen, mit den folgenden Werten eine Markierung auf dem Rohr anzubringen.</p>
<p>Profondeur d'emmanchement du tube FR</p> <p>La connexion correcte du raccord est confirmée par le repère de connexion (flèche) pré-tamponné sur le tube. En cas de coupe du tube, il est recommandé de reporter le repère de connexion sur le tube à l'aide du gabarit ou d'un marqueur et d'un mètre en utilisant les valeurs suivantes.</p>	<p>Conexión del tubo ES</p> <p>La correcta conexión del tubo está confirmada por la posición de la flecha pre-marcada. En el caso de existir la necesidad de cortar el tubo, desbarbar el extremo del tubo y marcar la longitud del tubo que va a insertar en el racor según la tabla adjunta.</p>	<p>Inserção do tubo PT</p> <p>O engate correto da conexão com o tubo é confirmada pela posição da seta que está impressa em todos os tubos. Em caso de necessidade de se cortar o tubo, marque no tubo as distâncias mostradas na tabela abaixo (de acordo com o diâmetro). Elas garantem a perfeita montagem entre a conexão e o tubo e evitando vazamentos.</p>

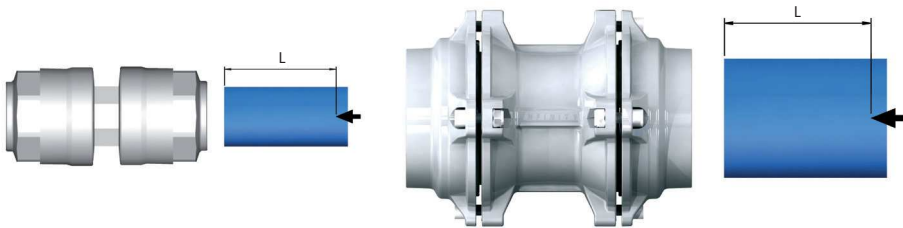

Ø мм	L мм
20	31.5
25	38.5
32	46
40	52
50	63.5
63	57.5
80	91
110	125.5



<p>Пропускная способность RU</p> <p>Пропускная способность для разных диаметров: Ø 20 расход до 2000 Нл/мин Ø 25 расход до 3500 Нл/мин Ø 32 расход до 7000 Нл/мин</p>	<p>Tube diameter for the outlets GB</p> <p>Specifications about available tube diameters for the outlets: Ø 20 with flow rate till 2000 NI/min Ø 25 with flow rate till 3500 NI/min Ø 32 with flow rate till 7000 NI/min</p>	<p>Durchflussleistung DE</p> <p>Durchflussleistung für verschiedene Durchmesser: Ø 20 mit einer Kapazität bis zu 2000 NI/min Ø 25 mit einer Kapazität bis zu 3500 NI/min Ø 32 mit einer Kapazität bis zu 7000 NI/min</p>
<p>Performance de débit FR</p> <p>Performance de débit pour les différents diamètres: Ø 20 avec une capacité jusqu'à 2000 NI/min Ø 25 avec une capacité jusqu'à 3500 NI/min Ø 32 avec une capacité jusqu'à 7000 NI/min</p>	<p>Tuberías secundarias (bajantes) ES</p> <p>Para elegir el Ø del bajante considerar: 2000 NI/min para Ø 20 3500 NI/min para Ø 25 7000 NI/min para Ø 32</p>	<p>Diâmetro dos tubos para as saídas PT</p> <p>São previstas saídas para diâmetros: Ø 20 com vazões até 2000 NI/min Ø 25 com vazões até 3500 NI/min Ø 32 com vazões até 7000 NI/min</p>



<p>Расчет сети RU</p> <p>Таблица позволяет определить диаметр магистральной линии.</p> <ol style="list-style-type: none"> 1 В красной колонке введите производительность компрессора. 2 Задайте расстояние между компрессором и самым удаленным пунктом в колонке № 1. 3 В месте пересечения колонки и строки найдите значение диаметра. 	<p>Chose the diameter four the installation GB</p> <p>The Diagram allows to determinate the diameter of the main line.</p> <ol style="list-style-type: none"> 1 Choose the Flow rate of compressor in the Red column. 2 Choose the Distance between compressor and the most distant using point in the 1° column. 3 Cross the lines of Flow rate and blue column of Distance to choose the diameter. 	<p>Dimensionierung des Netzes DE</p> <p>Die folgende Tabelle gibt die Möglichkeit den Durchmesser der Hauptleitung zu bestimmen.</p> <ol style="list-style-type: none"> 1 Wählen Sie die Durchflussmenge des Kompressors in der roten Spalte. 2 Wählen sie die Distanz zwischen Kompressor und dem weitesten Punkt im Netz in der 1° Spalte. 3 Der Durchmesser wird durch den Schnittpunkt der Spalte und der Zeile festgelegt.
<p>Dimensionner son réseau FR</p> <p>Le diagramme permet de déterminer le diamètre de l'alimentation principale.</p> <ol style="list-style-type: none"> 1 Choisir le débit du compresseur dans la colonne rouge. 2 Choisir la distance entre le compresseur et le point le plus éloigné dans la colonne 1°. 3 Le diamètre conseillé est défini par l'intersection des deux valeurs. 	<p>Dimensión de la red ES</p> <p>La tabla siguiente permite determinar el diámetro de la línea principal.</p> <ol style="list-style-type: none"> 1 Localizar el caudal del compresor en la columna de la izquierda. 2 Encontrar la distancia del compresor al punto más lejano de utilización en la columna 1°. 3 Determinar el diámetro en la intersección de la columna del caudal con la columna de la distancia. 	<p>Dimensionamento da rede PT</p> <p>A tabela permite determinar o diâmetro da linha principal.</p> <ol style="list-style-type: none"> 1 Encontre a linha de vazão do compressor na coluna vermelha. 2 Encontre a distância entre o compressor e o ponto de utilização mais distante nas colunas 1°. 3 Encontre o diâmetro cruzando a linha da vazão do compressor com a coluna da distância.

Пропускная способность Flow Rate Durchflusswert Débit de Reference Caudal Vazão			Расстояние от компрессора до наиболее удаленной точки разбора Distance between compressor and the most distant using point Distanz zwischen Kompressor und dem weitesten Punkt Distance entre le compresseur et le point le plus éloigné Distancia del compresor al punto más lejano de utilización Distância entre o compressor e o ponto de utilização mais distante										
Нл/мин	Нм3/ч	куб. футов в мин.	25 м 82 фт	50 м 164 фт	100 м 328 фт	150 м 492 фт	200 м 656 фт	300 м 984 фт	400 м 1312 фт	500 м 1640 фт	1000 м 3280 фт	1500 м 4921 фт	2000 м 6562 фт
230	14	8	20	20	20	20	20	20	20	20	20	25	25
650	39	23	20	20	20	20	25	25	25	25	32	32	40
900	54	32	20	20	25	25	25	32	32	32	40	40	40
1200	72	42	20	20	25	25	32	32	32	32	40	40	50
1750	105	62	20	25	32	32	32	40	40	40	50	50	50
2000	120	71	25	25	32	32	32	40	40	40	50	50	50
2500	150	88	25	32	32	32	40	40	40	50	50	63	63
3000	180	106	25	32	32	40	40	40	50	50	50	63	63
3500	210	124	25	32	40	40	40	50	50	50	63	63	63
4500	270	159	32	32	40	40	50	50	50	50	63	63	80
6000	360	212	32	40	50	50	50	50	63	63	80	80	80
7000	420	247	32	40	50	50	50	63	63	63	80	80	80
8500	510	300	40	40	50	50	63	63	63	63	80	80	110
12000	720	424	40	50	63	63	63	80	80	80	110	110	110
15000	900	530	50	50	63	63	80	80	80	80	110	110	110
18000	1080	636	50	63	63	80	80	80	80	110	110	110	110
21000	1260	742	50	63	63	80	80	80	110	110	110	110	110
26000	1560	918	63	63	80	80	80	110	110	110	110	110	110
31000	1860	1095	63	63	80	80	110	110	110	110	110	110	110*
33000	1980	1165	63	80	80	110	110	110	110	110	110	110*	110*
44000	2640	1554	63	80	110	110	110	110	110	110	110*	110*	110*
50000	3000	1766	80	80	110	110	110	110	110	110	110*	110*	110*
58000	3480	2048	80	80	110	110	110	110	110	110	110*	110*	110*
67000	4020	2366	80	110	110	110	110	110	110	110*	110*	110*	110*
75000	4500	2648	80	110	110	110	110	110	110*	110*	110*	110*	110*
83000	4980	2931	80	110	110	110	110	110*	110*	110*	110*	110*	110*
92000	5520	3249	110	110	110	110	110	110*	110*	110*	110*	110*	110*
100000	6000	3531	110	110	110	110	110	110*	110*	110*	110*	110*	110*

Давление 7 бар - Полные потери давления 4%

Pressure 7 bar - Total pressure drop 4%

Druck 7 bar - Druckverlust 4%

Pression 7 bar - Perte de charge 4%

Valores referidos a una presión de 7 bar - Pérdida de carga máx. total 4%

Pressão 7 bar - Queda de pressão total 4%

*** Потери давления более 4%**

Pressure drop is higher than 4%

Druckverlust von mehr als 4%

Perte de charge supérieure à 4%

La pérdida de carga es superior al 4%

A queda de pressão é superior aos 4%

Пример	RU	Example	GB	Beispiel	DE
<ul style="list-style-type: none"> Производительность: 3000 Нл/мин Расстояние между компрессором и наиболее удаленной точки разбора: 300 м Диаметр трубы: 40 мм 		<ul style="list-style-type: none"> Flow rate: 3000 NI/min Distance between compressor and most distant using point: 300 m Tube diameter: 40 mm 		<ul style="list-style-type: none"> Durchfluss: 3000 NI/min Distanz zwischen Kompressor und dem weitesten Punkt: 300 m Rohr Durchmesser: 40 mm 	
<ul style="list-style-type: none"> Débit: 3000 NI/min Distance entre le compresseur et le point le plus éloigné: 300 m Diamètre du tube: 40 mm 	FR	<ul style="list-style-type: none"> Caudal: 3000 NI/min Distancia del compresor al punto más lejano de la instalación: 300 m Se recomienda diámetro tubo: 40 mm 	ES	<ul style="list-style-type: none"> Vazão: 3000 NI/min Distância entre o compressor e o ponto de utilização mais distante: 300 m Diâmetro do tubo: 40 mm 	PT



Условная производительность компрессора при 7 бар

Indicative flow rates of the compressors to 7 bar

Durchflussmengen der Kompressoren bei 7 bar

Indications des débits des compresseurs à 7 bar

Caudal indicativo de compresores a 7 bar

Vazões inidcativas dos compresores a 7 bar



кВт	CV	Нл/мин
1.5	2	230
3	4	460
4	6	650
5.5	7,5	900
7.5	10	1200
11	15	1750
12.5	17	2000
15	20	2500
18	25	3000
22	30	3500
29	40	4500
37	50	6000
45	60	7000
55	75	8500
74	100	12000
92	125	15000
110	150	18000
132	180	21000
170	230	26000
200	270	31000
250	340	44000

Расстояние от компрессора до наиболее удаленной точки разбора

Distance between compressor and the most distant using point

Distanz zwischen Kompressor und dem weitesten Punkt

Distance entre le compresseur et le point le plus éloigné.

Distancia del compresor al punto más lejano de utilización.

Distância entre o compressor e o ponto de utilização mais distante.

ЗАКОЛЬЦОВАННАЯ МАГИСТРАЛЬ

- LOOP SYSTEM
- KREISLAUF SYSTEM
- RÉSEAU BOUCLÉ
- ANILLO CERRADO
- LINHA EM ANEL FECHADO

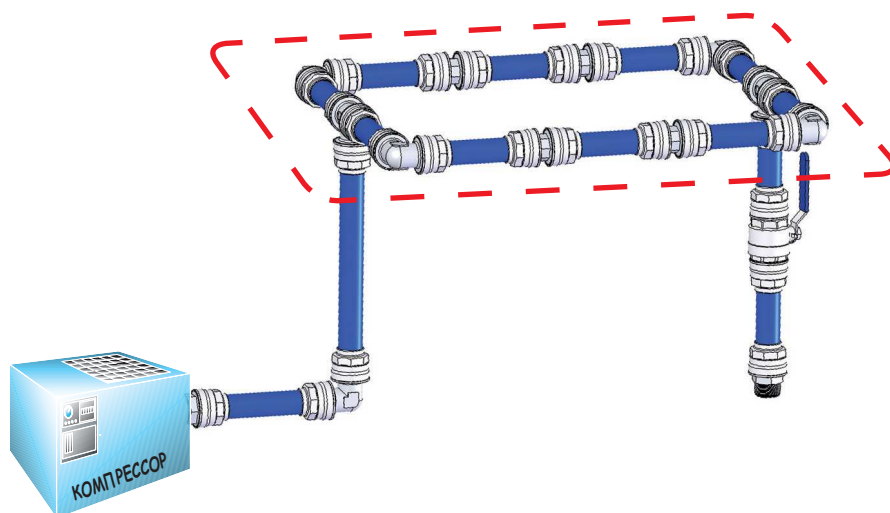

ЛИНЕЙНАЯ МАГИСТРАЛЬ

- LINEAR SYSTEM
- LINEARES SYSTEM
- RÉSEAU NON BOUCLÉ
- SISTEMA LINEAL
- LINHA ABERTA

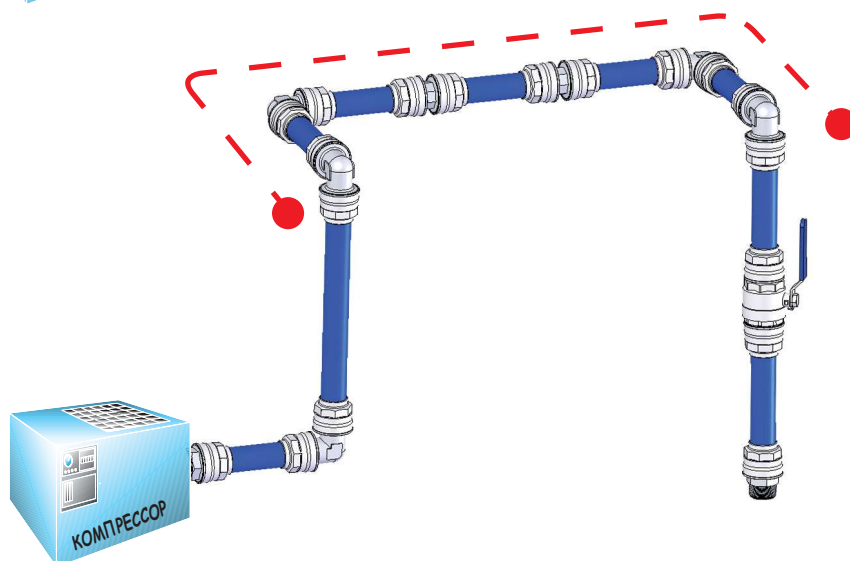

Линейные системы рекомендуются на расход не более 1200 Нл/мин

Line Blind is only recommended for consumption below the 1200 Nl/m.

Lineare Systeme werden nur für den Einsatz unterhalb von 1200 Nl/m empfohlen.

Cette typologie de réseau n'est recommandée que pour des consommations en dessous de 1200 Nl/min.

Sistema lineal solamente para el consumo menores de 1200 Nl/m.

A linha aberta é aconselhável apenas para consumo inferior a 1200 Nl/m.



Тепловое расширение и сжатие

RU

Для расчета расширения/сжатия мы можем использовать следующую формулу:

$$\Delta L = \Delta T \times L \times \alpha \quad \text{где это:}$$

ΔL = линейное расширение/сжатие в мм
 ΔT = разность температуры между рабочей температурой и температурой монтажа °C
 L = длина трубопровода в м
 α = коэффициент теплового расширения алюминия 0,024 мм/м °C

Система должна располагаться с учетом свободного пространства, обеспечивающего свободное расширение-сжатие, элементы подвеса должны располагаться в соответствии со схемой, показанной на рис.:

Expansion and shrinkage due to the heat

GB

To calculate the linear expansion - shrinkage we can use the following formula:

$$\Delta L = \Delta T \times L \times \alpha \quad \text{i.e.:$$

ΔL = Linear expansion - shrinkage in mm
 ΔT = Heat variation between the operating temperature and the installation one at °C
 L = Tube length in m
 α = Linear expansion factor, for the aluminium it is 0.024 mm/m °C

The installation have to be positioned, considering at the two ends free space which permits the expansion - shrinkage and supports have to be fixed as showed in the picture:

Thermische Ausdehnung + Kontraktion

DE

Zur Berechnung der linearen Ausdehnung / Kontraktion kann folgende Formel verwendet werden:

$$\Delta L = \Delta T \times L \times \alpha \quad \text{wobei:}$$

ΔL = lineare Ausdehnung / Kontraktion in mm
 ΔT = Temperaturunterschied zwischen der Betriebs- und Umgebungstemperatur in °C
 L = Rohrlänge in m
 α = linearer Ausdehnungskoeffizient; für Aluminium ist er 0.024 mm/m °C

Die Installation muss so positioniert werden, dass an beiden Enden ein Freiraum berücksichtigt wird, welcher die Ausdehnung / Kontraktion erlaubt und die Halterungen müssen wie auf dem Bild gezeigt befestigt werden:

Dilatation + contraction

FR

Pour calculer la dilatation linéaire, la formule suivante peut être utilisée:

$$\Delta L = \Delta T \times L \times \alpha \quad \text{i.e.:$$

ΔL = Dilatation linéaire en mm
 ΔT = Delta de température (installation/utilisation) en °C
 L = Longueur de l'installation en m
 α = coefficient de dilatation linéaire de l'aluminium = 0.024 mm/m °C

Les extrémités de l'installation doivent être libre afin de permettre une dilatation des tubes .
 Les points de fixation des tubes doivent être disposés selon le dessin suivant:

Las dilataciones y contracciones termicas

ES

El calculo de Las dilataciones y contracciones termicas se basa segun la formula:

$$\Delta L = \Delta T \times L \times \alpha \quad \text{i.e.:$$

ΔL = Dilatacion Lineal - contraccion mm
 ΔT = variación térmica entre temperatura de trabajo y instalación °C
 L = Longitud del tubo m
 α = Factor dilatacion lineal de aluminio 0.024 mm/m °C

Considerando que ambos extremos están libre y permiten dilatacion y contraccion, la instalación debe ser realizada como en la imagen:

Dilatações e contrações térmicas

PT

Para calcular a dilatação - contração linear utilizamos a seguinte fórmula:

$$\Delta L = \Delta T \times L \times \alpha \quad \text{onde:}$$

ΔL = dilatação - contração linear em mm
 ΔT = variação de temperatura entre a temperatura de trabalho e a de instalação em °C
 L = comprimento do tubo em m
 α = coeficiente de dilatação térmica linear que para o alumínio é 0.024 mm/m °C

A instalação deve ser feita de modo que nas extremidades se considere um espaço de permita a dilatação-contração, e os suportes devem ser posicionados como mostra a figura:

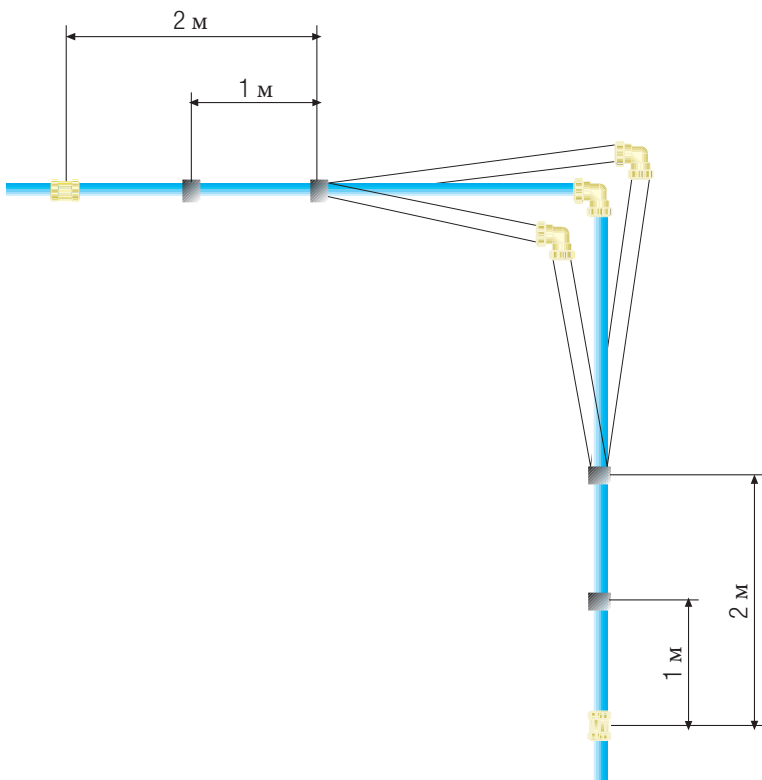

ТРУБЫ АЛЮМИНИЕВЫЕ КАЛИБРОВАННЫЕ

КАЛИБРОВАННЫЕ АЛЮМИНИЕВЫЕ ТРУБЫ, ЦВЕТ СИНИЙ
 ALUMINIUM ROHR KALIBRIERT
 TUBE ALUMINIUM CALIBRE
 TUBO EN ALUMINIO CALBRADO
 TUBOS EM ALUMÍNIO CALIBRADOS

90000 - 4 м

цвет:

СИНИЙ
 BLUE
 BLAU
 BLEU
 AZUL OSCURO
 AZUL



Код	Ø	Толщина	Давление	Удельная масса	Длина	Упак.
		Thickness Dicke Épaisseur Espesor Espessura				
	мм	мм	бар	г/м	м	
90000 00 11 Y9 B5	20	1.5	16	235	4 м	8
90000 00 11 J4 B5	25	1.5	16	298	4 м	8
90000 00 11 J9 B5	32	1.5	16	387	4 м	9
90000 00 11 K4 B5	40	1.5	16	490	4 м	9
90000 00 11 W0 B5	50	2	16	814	4 м	4
90000 00 11 W3 B5	63	2	16	1034	4 м	4
90000 00 11 TP B5	80	2	16	1283	4 м	2
90000 00 11 HT B5	110	2.5	16	2280	4 м	2

90000 - 4 м

цвет:

СЕРЫЙ
 GRAY
 GRAU
 GRIS
 GRIS
 CINZA



Код	Ø	Толщина	Давление	Удельная масса	Длина	Упак.
		Thickness Dicke Épaisseur Espesor Espessura				
	мм	мм	бар	г/м	м	
90000 00 11 Y9 GR	20	1.5	16	235	4 м	8
90000 00 11 J4 GR	25	1.5	16	298	4 м	8
90000 00 11 J9 GR	32	1.5	16	387	4 м	9
90000 00 11 K4 GR	40	1.5	16	490	4 м	9
90000 00 11 W0 GR	50	2	16	814	4 м	4
90000 00 11 W3 GR	63	2	16	1034	4 м	4
90000 00 11 TP GR	80	2	16	1283	4 м	2
90000 00 11 HT GR	110	2.5	16	2280	4 м	2

90000 - 6 м

цвет:

СИНИЙ
 BLUE
 BLAU
 BLEU
 AZUL OSCURO
 AZUL

Код	Ø	Толщина	Давление	Удельная масса	Длина	Упак.
		Thickness Dicke Epaisseur Espesor E spessore	Pressures Druckbereich Pressions Presiones Pressões	Weight Gewicht Poids Peso Peso	Lenght Länge Long Longitud Comprimento	
	мм	мм	бар	г/м	м	
90000 6 020 BL	20	1.5	16	235	6 м	8
90000 6 025 BL	25	1.5	16	298	6 м	8
90000 6 032 BL	32	1.5	16	387	6 м	9
90000 6 040 BL	40	1.5	16	490	6 м	4
90000 6 050 BL	50	2	16	814	6 м	4
90000 6 063 BL	63	2	16	1034	6 м	2
90000 6 080 BL	80	2	16	1283	6 м	2
90000 6 110 BL	110	2.5	16	2280	6 м	1

90000 - 6 м

цвет:

СЕРЫЙ
 GRAY
 GRAU
 GRIS
 GRIS
 CINZA

Код	Ø	Толщина	Давление	Удельная масса	Длина	Упак.
		Thickness Dicke Epaisseur Espesor E spessore	Pressures Druckbereich Pressions Presiones Pressões	Weight Gewicht Poids Peso Peso	Lenght Länge Long Longitud Comprimento	
	мм	мм	бар	г/м	м	
90000 6 020 GR	20	1.5	16	235	6 м	8
90000 6 025 GR	25	1.5	16	298	6 м	8
90000 6 032 GR	32	1.5	16	387	6 м	9
90000 6 040 GR	40	1.5	16	490	6 м	4
90000 6 050 GR	50	2	16	814	6 м	4
90000 6 063 GR	63	2	16	1034	6 м	2
90000 6 080 GR	80	2	16	1283	6 м	2
90000 6 110 GR	110	2.5	16	2280	6 м	1

90000 - 6 м

цвет:

ЗЕЛЕНый
 GREEN
 GRÜN
 VERT
 VERDE
 VERDE

Код	Ø	Толщина	Давление	Удельная масса	Длина	Упак.
		Thickness Dicke Epaisseur Espesor E spessore	Pressures Druckbereich Pressions Presiones Pressões	Weight Gewicht Poids Peso Peso	Lenght Länge Long Longitud Comprimento	
	мм	мм	бар	г/м	м	
90000 6 020 VE	20	1.5	16	235	6 м	8
90000 6 025 VE	25	1.5	16	298	6 м	8
90000 6 032 VE	32	1.5	16	387	6 м	9
90000 6 040 VE	40	1.5	16	490	6 м	4
90000 6 050 VE	50	2	16	814	6 м	4
90000 6 063 VE	63	2	16	1034	6 м	2
90000 6 080 VE	80	2	16	1283	6 м	2
90000 6 110 VE	110	2.5	16	2280	6 м	1

ВТЫЧНЫЕ ФИТИНГИ ДЛЯ МОНТАЖА ТРУБОПРОВОДОВ СЖАТОГО ВОЗДУХА

PUSH-IN FITTINGS FOR INSTALLATION OF COMPRESSED-AIR PIPELINES
 STECKVERSCHRAUBUNGEN FÜR DIE INSTALLATION VON DRUCKLUFT-VERTEILSYSTEMEN
 RACCORDS INSTANTANÉS POUR RÉSEAUX PRIMAIRES
 REDES DE AIRE COMPRIMIDO
 CONEXÕES AUTOMÁTICAS PARA A INSTALAÇÃO DE REDES DE AR COMPRIMIDO

90010

НОВИНКА

АДАПТЕР ПРЯМОЙ С НАРУЖНОЙ РЕЗЬБОЙ

STRAIGHT MALE ADAPTOR
 GERADE EINSCHRAUBVERSCHRAUBUNG
 RACCORD DROIT MÂLE
 RACOR RECTO MACHO
 CONEXÃO RETA COM ROSCA MACHO

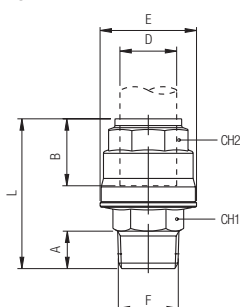

Код	D	F	A	B	E	L	CH1	CH2	Упак.
90010 00 001	20	1/2	14	31.5	34.5	56	22	30	5
90010 00 009	20	3/4	16.5	31.5	34.5	61	22	30	5
90010 00 011	25	1/2	14	38.5	42.5	65	27	35	5
90010 00 002	25	3/4	16.5	38.5	42.5	66	27	35	5
90010 00 010	25	1"	19	38.5	42.5	70.5	27	35	5
90010 00 003	32	1"	19	46	52	76.5	34	45	2
90010 00 013	40	1"	19	52	63	86.5	45	55	2
90010 00 004	40	1"1/4	21.5	52	63	89.5	45	55	2
90010 00 007	40	1"1/2	21.5	52	63	92	50	55	2
90010 00 014	50	1"	19	63.5	73	102.5	60	65	2
90010 00 005	50	1"1/2	21.5	63.5	73	105	50	65	2
90010 00 012	50	2"	24	-	73	111	60	65	2
Алюминий - Aluminium - Aluminium - Aluminium - Aluminium - Alumínio									
90010 00 006 A	63	2"	24	57.5	94	109.5	65	75	2
90010 00 008 A	63	2"1/2	24	57.5	94	106.5	75	75	2

90011

NPTF

АДАПТЕР ПРЯМОЙ С НАРУЖНОЙ РЕЗЬБОЙ

STRAIGHT MALE ADAPTOR
 GERADE EINSCHRAUBVERSCHRAUBUNG RACCORD
 DROIT MÂLE
 RACOR RECTO MACHO
 CONEXÃO RETA COM ROSCA MACHO

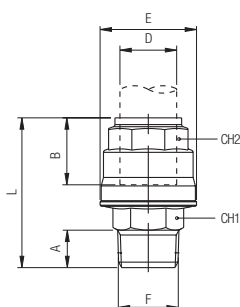

Код	D	F (NPTF)	A	B	E	L	CH1	CH2	Упак.
90011 00 001	20	1/2	14	31.5	34.5	56	22	30	5
90011 00 002	25	3/4	16.5	38.5	42.5	66	27	35	5
90011 00 003	32	1"	19	46	52	76.5	34	45	2
90011 00 004	40	1"1/2	21.5	52	63	89.5	45	55	2
90011 00 005	50	1"1/2	21.5	63.5	73	105	50	65	2
Алюминий - Aluminium - Aluminium - Aluminium - Aluminium - Alumínio									
90011 00 006 A	63	2"	23.5	57.5	94	109.5	65	75	2

90012

РЕДУКЦИЯ ТРУБНАЯ

TUBE-TUBE REDUCER
 REDUKTION ROHR-ROHR
 RÉDUCTION TUBE-TUBE
 REDUCCIÓN TUBO-TUBO
 REDUÇÃO TUBO-TUBO

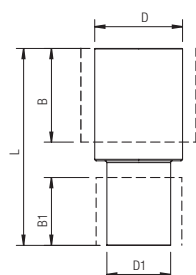

Код	D	D1	B	B1	L	Упак.
90012 00 001	80	63	91	57.5	168	1
90012 00 002	110	80	150.5	91	247	1

90013

НОВИНКА

АДАПТЕР ФЛАНЦЕВЫЙ

FLANGED TUBE
FLANSCHANSCHLUSS
BRIDE CIRCULAIRE
TUBO BRIDA
TUBO FLANGEADO

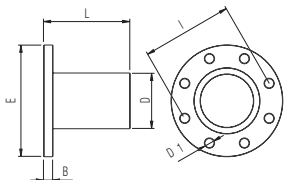

Код	D	B	C	E	F	L	D1	I	Упак.
90013 00 001	80	25	20	200	130	131	18	160	1
90013 00 002	110	25	20	220	158	166	18	180	1

Присоединительные размеры фланца соответствуют стандарту UNI EN 1092 - 4 PN 16 (фланец из алюминиевого сплава).

The connection dimensions of the flange are designed in conformity with standard UNI EN 1092 - 4 PN 16 (Flange made in aluminium alloy).

Die Abmessungen der Flanschverbindung entsprechen der Norm UNI EN 1092 - 4 PN 16 (Flansch aus Aluminiumlegierung).

Les dimensions de raccordement de la bride sont conforme avec la norme UNI EN 1092 - 4 PN 16 (Bride faite en alliage d'aluminium).

Las dimensiones de acoplamiento de la brida, respetan la norma UNI EN 1092 - 4 PN 16 (Brida en aleación de aluminio).

As dimensões de acoplamento da flange respeitam a norma UNI EN 1092 - 4 PN 16 (Flange fabricada em liga de alumínio).

90014

НОВИНКА ANSI 150-LB

АДАПТЕР ФЛАНЦЕВЫЙ

FLANGED TUBE
FLANSCHANSCHLUSS
BRIDE CIRCULAIRE
TUBO BRIDA
TUBO FLANGEADO

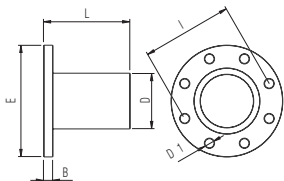

Код	D	B	C	E	F	L	D1	I	Упак.
90014 00 001	80	25	20	190.5	130	131	19	152.4	1
90014 00 002	110	25	20	228.6	158	166	19	190.5	1

Присоединительные размеры фланца соответствуют стандарту ANSI 150-LB (фланец из алюминиевого сплава).

The connection dimensions of the flange are designed in conformity with standard ANSI 150-LB (Flange made in aluminium alloy).

Die Abmessungen der Flanschverbindung entsprechen der Norm ANSI 150-LB (Flansch aus Aluminiumlegierung).

Les dimensions de raccordement de la bride sont conforme avec la norme ANSI 150-LB (Bride faite en alliage d'aluminium).

Las dimensiones de acoplamiento de la brida, respetan la norma ANSI 150-LB (Brida en aleación de aluminio).

As dimensões de acoplamento da flange respeitam a norma ANSI 150-LB (Flange fabricada em liga de alumínio).

90015

АДАПТЕР ФЛАНЦЕВЫЙ

FLANGED TUBE
FLANSCHANSCHLUSS
BRIDE CIRCULAIRE
TUBO BRIDA
TUBO FLANGEADO

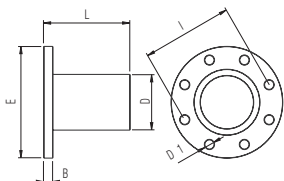

Код	D	B	E	L	D1	I	Упак.
90015 00 002	80	20	200	155	18	160	1
90015 00 001	110	20	220	183	18	180	1

**Снят с производства.
Продажи до завершения складского запаса**

Until the end stock

Nur solange vorrat

Livvable jusqu'à épuisement du stock

Hasta fin de stock

Ate fim do stock

Присоединительные размеры фланца соответствуют стандарту UNI EN 1092 - 4 PN 16 (фланец из алюминиевого сплава).

The connection dimensions of the flange are designed in conformity with standard UNI EN 1092 - 4 PN 16 (Flange made in aluminium alloy).

Die Abmessungen der Flanschverbindung entsprechen der Norm UNI EN 1092 - 4 PN 16 (Flansch aus Aluminiumlegierung).

Les dimensions de raccordement de la bride sont conforme avec la norme UNI EN 1092 - 4 PN 16 (Bride faite en alliage d'aluminium).

Las dimensiones de acoplamiento de la brida, respetan la norma UNI EN 1092 - 4 PN 16 (Brida en aleación de aluminio).

As dimensões de acoplamento da flange respeitam a norma UNI EN 1092 - 4 PN 16 (Flange fabricada em liga de alumínio).

90017

ПЛОСКАЯ ФЛАНЦЕВАЯ ПРОКЛАДКА

FLAT GASKET FOR FLANGE
FLACHDICHTUNG FÜR FLANSCH
JOINT POUR BRIDE CIRCULAIRE
JUNTA PARA BRIDA (RECAMBIO)
VEDAÇÃO PLANA PARA FLANGE
(REPOSIÇÃO)

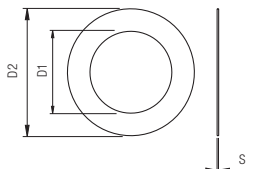

Код	Труба	D1	D2	S	Упак.
90017 00 57 TP 00	80	89	131	2	1
90017 00 57 HT 00	110	115	162	2	1

90018

АДАПТЕР ФЛАНЦЕВЫЙ

FLANGED TUBE
 FLANSCHANSCHLUSS
 BRIDE CIRCULAIRE
 TUBO BRIDA
 TUBO FLANGEADO

ANSI 150-LB

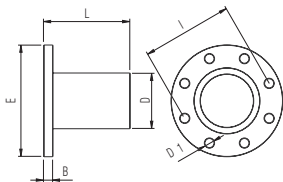

Код	D	B	E	L	D1	I	Упак.
90018 00 007	80	20	190.5	155	19	152.5	1
90018 00 008	110	20	228.5	183.5	19	190.5	1

Снят с производства.
Продажи до завершения складского запаса
Until the end stock
Nur solange vorrat
Livable jusqu'à épuisement du stock
Hasta fin de stock
Ate fim do stock

Присоединительные размеры фланца соответствуют стандарту ANSI 150-LB

(фланец из алюминиевого сплава).

The connection dimensions of the flange are designed in conformity with standard ANSI 150-LB (Flange made in aluminium alloy).

Die Abmessungen der Flanschverbindung entsprechen der Norm ANSI 150-LB (Flansch aus Aluminiumlegierung).

Les dimensions de raccordement de la bride sont conforme avec la norme ANSI 150-LB (Bride faite en alliage d'aluminium).

Las dimensiones de acoplamiento de la brida, respetan la norma ANSI 150-LB (Brida en aleación de aluminio).

As dimensões de acoplamento da flange respeitam a norma ANSI 150-LB (Flange fabricada em liga de alumínio).

90019

КРЕПЕЖНЫЙ КОМПЛЕКТ ФЛАНЦЕВЫЙ

FLANGE KIT
 SET SCHRAUBEN FÜR FLANSCH
 KIT BOULON / ECROU POUR BRIDE
 KIT TORNILLOS PARA BRIDA
 KIT DE PARAFUSOS PARA FLANGE



Код	Резьба	Размер	Упак.
90019 00 001	M16	65 мм	1

KIT: 8 болтов + 8 гаек + 16 шайб

KIT: 8 screw + 8 nut + 16 washer

SET: 8 Schrauben + 8 Muttern + 16 Scheiben

KIT: 8 vis + 8 ecrous + 16 rondelles

KIT: 8 tornillos + 8 tuercas + 16 arandelas

KIT: 8 parafusos + 8 porcas + 16 arruelas

Монтаж 90015 - 90018

IT

- 1 Для подключения системы к компрессору используйте фланцевый адаптер 90015.
- 2 Установите прокладку № арт. 90017 между фланцем компрессора и № арт. 90015. Затяните восемь болтов № арт. 90019. Момент затяга 60 Нм.

Assembling 90015 - 90018

GB

- 1 To connect the pipe system to the compressor use flanged tube art.90015
- 2 Lay flange gasket art. 90017 between compressor flange and art. 90015. Tighten the eight screws art. 90019. Tightening torque 60 Nm.

Montageanleitung 90015 - 90018

DE

- 1 Um das Netz an den Kompressor anzuschliessen, kann der Flanschanschluss Art. 90015 verwendet werden.
- 2 Legen Sie die Flachdichtung Art. 90017 zwischen den Flansch des Kompressors und dem Flanschanschluss Art. 90015. Ziehen Sie die acht Schrauben Art. 90019 mit einem Drehmoment von 60 Nm an.

Assemblage 90015 - 90018

FR

Utilisation de la bride circulaire art. 90015 pour connecter le réseau au compresseur.
Placez le joint art. 90 017 entre la bride du compresseur et la bride circulaire art. 90015. Serrer les huit vis de l'article. 90019 à un couple de serrage de 60 Nm.

Montaje 90015 - 90018

ES

- 1 Para conectar la instalación al compresor utilizar el tubo brida Art. 90015.
- 2 Colocar la junta art. 90017 tras la brida del compresor Art. 90015. Apretar los ocho tornillos Art. 90019. Esfuerzo de torsión 60 Nm.

Montagem 90015 - 90018

PT

- 1 Para conectar o tubo ao compressor utilize o tubo flangeado cód. 90015.
- 2 Coloque a anel de vedação cód. 90017 entre a flange do compressor e o tubo flangeado cód. 90015. Aperte os oito parafusos cód. 90019. Torque de aperto 60 Nm.

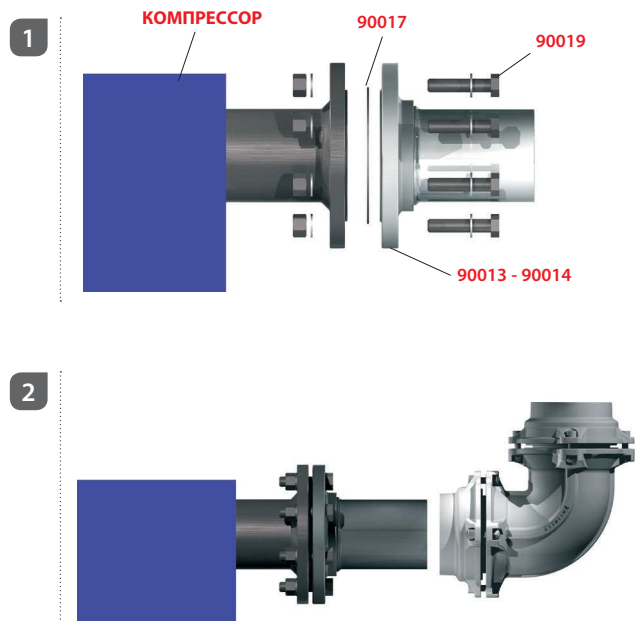

90020

НОВИНКА

РЕДУКЦИЯ С ТРУБЫ НА НАРУЖНУЮ РЕЗЬБУ

TUBE-MALE REDUCER
EINSCHRAUBVERSCHRAUBUNG-ROHR
ADAPTEUR TUBE-MÂLE
ADAPTADOR TUBO-MACHO
REDUÇÃO TUBO- ROSCA MACHO

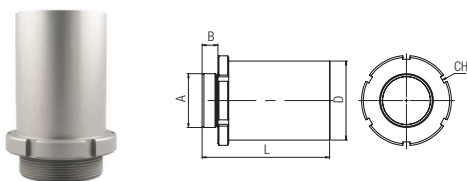

Код	D	A	B	L	CH*	Упак.
90020 00 003	80	2"-1/2	22	143	100	1
90020 00 004	80	3"	23	144	100	1
90020 00 001	110	2"-1/2	22	178	125	1
90020 00 002	110	3"	23	179	125	1
90020 00 005	110	4"	23	179	125	1

***Размер крюкообразного ключа**

Hook wrench dimensions
Hakenschlüssel abmessungen
Dimensions de la clé à ergot
Dimensiones llave de gancho
Dimensões para chave tpo gancho

90030

АДАПТЕР С ВНУТРЕННЕЙ РЕЗЬБОЙ

STRAIGHT FEMALE ADAPTOR
AUFSCHRAUBVERSCHRAUBUNG
RACCORD DROIT, TARAUEE
RACOR RECTO HEMBRA
CONEXÃO RETA COM ROSCA FÊMEA

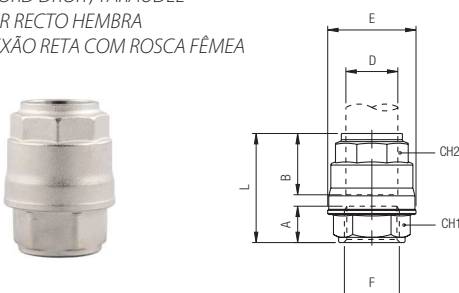

Код	D	F	A	B	E	L	CH1	CH2	Упак.
90030 00 001	20	1/2	15	31.5	34.5	49	24	30	5
90030 00 002	25	3/4	16.5	38.5	42.5	56.5	32	35	5
90030 00 003	32	1"	19	46	52	66.5	38	45	2
90030 00 004	40	1"1/4	22	52	63	76	50	55	2
90030 00 005	50	1"1/2	22	63.5	73	85.5	55	65	2

90040

СОЕДИНЕНИЕ ПРЯМОЕ

STRAIGHT CONNECTOR
 VERBINDUNGSVERSCHRAUBUNG
 RACCORD UNION DOUBLE
 RACOR RECTO INTERMEDIO
 CONEXÃO RETA TUBO-TUBO

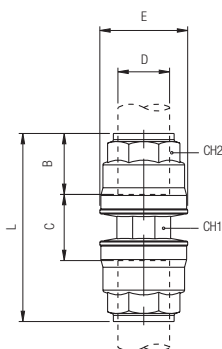

Код	D	B	C	E	L	CH1	CH2	Упак.
90040 00 001	20	31.5	14.5	34.5	76.5	21	30	2
90040 00 002	25	38.5	13.5	42.5	90.5	26	35	2
90040 00 003	32	46	14.5	52	106.5	32	45	2
90040 00 004	40	52	21	63	125	41	55	2
90040 00 005	50	63.5	21.5	73	148.5	50	65	2
Алюминий - Aluminium - Aluminium - Aluminium - Aluminio - Aluminio								
90040 00 006 A	63	57.5	44	94	159	73	75	1

90040 Ø 80-110

СОЕДИНЕНИЕ ПРЯМОЕ

STRAIGHT CONNECTOR
 VERBINDUNGSVERSCHRAUBUNG
 RACCORD UNION DOUBLE
 RACOR RECTO INTERMEDIO
 CONEXÃO RETA TUBO-TUBO

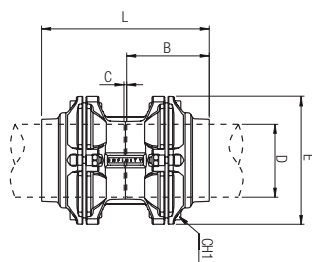

Код	D	B	C	E	L	CH1	Упак.
90040 00 007	80	91	3.5	145	186	6	2
90040 00 008	110	125.5	4	200	255	8	1

90130

СОЕДИНЕНИЕ УГЛОВОЕ

ELBOW CONNECTOR
 WINKELVERSCHRAUBUNG
 RACCORD EQUERRE
 RACOR A L INTERMEDIO
 CONEXÃO EM "L" TUBO-TUBO

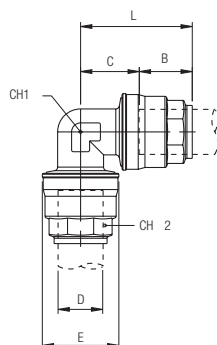

Код	D	B	C	E	L	CH1	CH2	Упак.
90130 00 001	20	31.5	19	34.5	51	21	30	4
90130 00 002	25	38.5	23	42.5	61.5	26	35	4
90130 00 003	32	46	28	52	74.5	34	45	2
90130 00 004	40	52	34	63	86.5	41	55	2
90130 00 005	50	63.5	40.5	73	104	50	65	2
Алюминий - Aluminium - Aluminium - Aluminium - Aluminio - Aluminio								
90130 00 006 A	63	57.5	55.5	94	113	73	75	1

90130 Ø 80-110

СОЕДИНЕНИЕ УГЛОВОЕ

ELBOW CONNECTOR
WINKELVERSCHRAUBUNG
RACCORD EQUERRE
RACOR A L INTERMEDIO
CONEXÃO EM "L" TUBO-TUBO

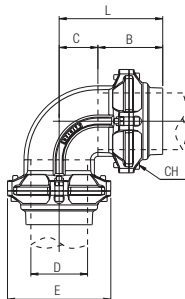

Код	D	B	C	E	L	CH	Упак.
90130 00 007	80	91	54.5	145	146	6	2
90130 000 08	110	125.5	75	200	200.5	8	1

90140

СОЕДИНЕНИЕ УГЛОВОЕ 135°

135° CONNECTOR
WINKELVERSCHRAUBUNG 135°
RACCORD EQUERRE A135°
RACOR INTERMEDIO 135°
CONEXÃO TUBO-TUBO 135°

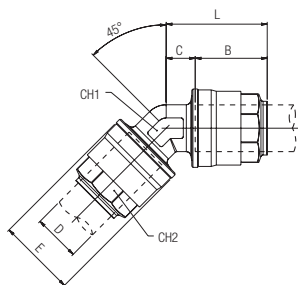

Код	D	B	C	E	L	CH1	CH2	Упак.
90140 00 001	20	31.5	12.5	34.5	44	21	30	4
90140 00 002	25	38.5	13.5	42.5	52	26	35	4
90140 00 003	32	46	15	52	61	34	45	2
90140 00 004	40	52	18	63	70	41	55	2
90140 00 005	50	63.5	20	73	83.5	50	65	2
Алюминий - Aluminium - Aluminium - Aluminium - Aluminium - Aluminium								
90140 00 006 A	63	57.5	24	94	82	73	75	1

90150

АДАПТЕР УГЛОВОЙ С НАРУЖН. КОНИЧЕСКОЙ РЕЗЬБОЙ

ELBOW CONNECTOR MALE-TUBE
EINSCHRAUBWINKEL KONISCH
RACCORD FILETÉ MÂLE
RACOR A L MACHO-TUBO
CONEXÃO EM "L" ROSCA MACHO-TUBO

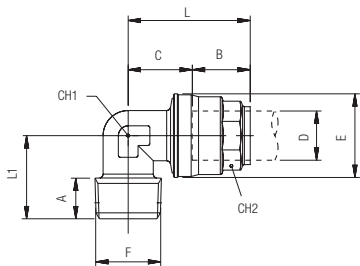

Код	D	F	A	B	C	E	L	L1	CH1	CH2	Упак.
90150 00 001	20	1/2	14	31.5	19	34.5	51	32	21	30	4
90150 00 002	25	3/4	16.5	38.5	23	42.5	61.5	37	26	35	4
90150 00 003	32	1"	19	46	28	52	74.5	49	34	45	2
90150 00 004	40	1"-1/4	21.5	52	34	63	86.5	54	41	55	2
90150 00 005	50	1"-1/2	21.5	63.5	40.5	73	104	59	50	65	2

90160

АДАПТЕР УГЛОВОЙ С ВНУТРЕННЕЙ РЕЗЬБОЙ

ELBOW CONNECTOR FEMALE-TUBE
 AUFSCHRAUBWINKEL ZYLINDRISCH
 RACCORD FILETÉ FEMELLE
 RACOR A L HEMBRA-TUBO
 CONEXÃO EM "L" ROSCA FÊMEA-TUBO

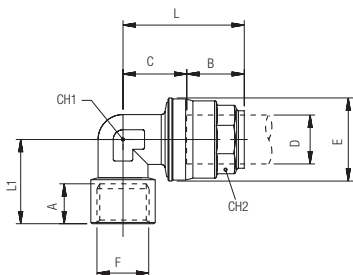

Код	D	F	A	B	C	E	L	L1	CH1	CH2	Упак.
90160 00 001	20	1/2	13	31.5	19	34.5	51	34.5	21	30	4
90160 00 002	25	3/4	14.5	38.5	23	42.5	61.5	38.5	26	35	4
90160 00 003	32	1"	16.5	46	28	52	74.5	47.5	34	45	2
90160 00 004	40	1"-1/4	20	52	34	63	86.5	56.5	41	55	2
90160 00 005	50	1"-1/2	22	63.5	40.5	73	104	64.7	50	65	2

90230

ТРОЙНИК

TEE CONNECTOR
 T-ANSCHLUSS
 RACCORD TÉ
 RACOR A T INTERMEDIO
 CONEXÃO EM "T" TUBO-TUBO

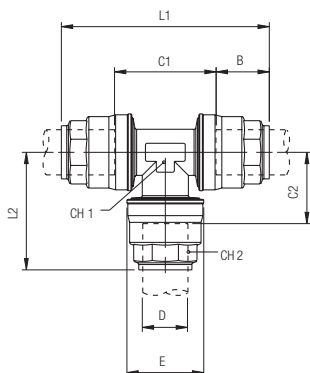

Код	D	E	B	C1	C2	L1	L2	CH1	CH2	Упак.
90230 00 001	20	34.5	31.5	34.5	22.5	98	54.5	21	30	3
90230 00 002	25	42.5	38.5	37.5	26	113.5	65	26	35	3
90230 00 003	32	52	46	46.5	31.5	138.5	77	34	45	2
90230 00 004	40	63	52	55.5	38	159.5	90	41	55	1
90230 00 005	50	73	63.5	69	44.5	196	108	50	65	1
Алюминий - Aluminium - Aluminium - Aluminium - Aluminium - Alumínio										
90230 00 006 A	63	94	57.5	111	55.5	226	113	73	75	1

90230 Ø 80-110

ТРОЙНИК

TEE CONNECTOR
 T-ANSCHLUSS
 RACCORD TÉ
 RACOR A T INTERMEDIO
 CONEXÃO EM "T" TUBO-TUBO

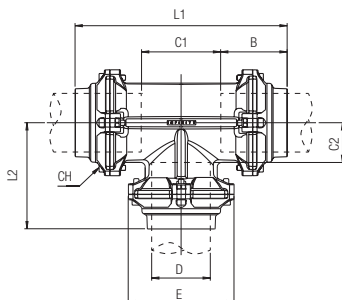

Код	D	E	B	C1	C2	L1	L2	CH	Упак.
90230 00 007	80	145	91	109	54.5	291.5	138	6	1
90230 00 008	110	200	125.5	150.5	75	401	200.5	8	1

90235

СОЕДИНЕНИЕ ПРОХОДНОЕ С РЕДУКЦ. ОТВОДОМ

FITTING FOR OUTLET

T-ANSCHLUSS REDUZIERT

TE RÉDUIT

RACOR A T PARA BAJANTE

CONEXÃO PARA SAÍDA DE AR

Код	D1	D2	B1	B2	C1	C2	E1	E2	L1	L2	CH	CH1	CH2	Упак.
90235 00 013	20	20	31.5	31.5	48	22.5	34.5	34.5	109	54	28	30	30	3
90235 00 001	25	20	38.5	31.5	45.5	27.5	42.5	34.5	121.5	59	35	35	30	3
90235 00 002	32	20	46	31.5	54.5	31.5	52	34.5	146.5	63	45	45	30	2
90235 00 003	32	25	46	38	54.5	31.5	52	42.5	146.5	70	45	45	35	2
90235 00 004	40	20	52.5	31.5	60	34.5	63	34.5	165.5	66	55	55	30	2
90235 00 005	40	25	52.5	38	60	34.5	63	42.5	165.5	73	55	55	35	2
90235 00 007	50	20	63.5	31.5	73.5	41.5	73	34.5	201	73	65	65	30	1
90235 00 008	50	25	63.5	38.5	73.5	41	73	42.5	201	80	65	65	35	1
90235 00 009	50	32	63.5	46	73.5	41	73	52	201	87.5	65	65	45	1

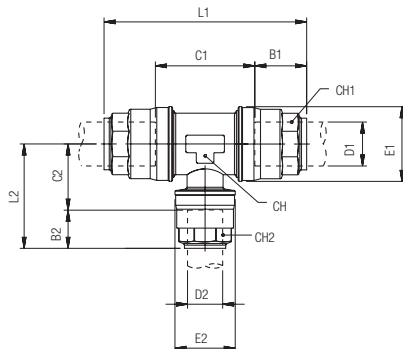

90236

СОЕДИНЕНИЕ ПРЯМОЕ С ОТВОДОМ С ВНУТР. РЕЗЬБОЙ

FEMALE FITTING FOR OUTLET

T-ANSCHLUSS MIT INNENGEWINDE

TÉ FILETÉ

RACOR PARA BAJANTE ROSCA HEMBRA

CONEXÃO PARA SAÍDA DE AR (ROSCA FÊMEA)

Код	D	F	A	B	C	E	L1	L2	CH	CH1	Упак.
90236 00 006	20	3/8	11	31.5	48	34.5	109	25	28	30	3
90236 00 007	20	1/2	13.5	31.5	48	34.5	109	28	28	30	3
90236 00 001	25	3/8	11	38.5	45.5	42.5	121.5	29	35	35	3
90236 00 008	25	1/2	13.5	38.5	45.5	42.5	121.5	31	35	35	2
90236 00 002	32	1/2	13.5	46	54.5	52	146.5	36.5	45	45	2
90236 00 003	40	1/2	13.5	52.5	60	63	165.5	41.5	55	55	2
90236 00 004	50	3/4	14.5	63.5	73.5	73	201	47.5	65	65	1
Алюминий - Aluminium - Aluminium - Aluminium - Aluminium - Aluminio											
90236 00 017 A	63	1/2	13.5	57.5	88	94	203	53	80	75	1
90236 00 005 A	63	3/4	14.5	57.5	88	94	203	54	80	75	1
90236 00 018 A	63	1"	17.5	57.5	88	94	203	56.5	80	75	1

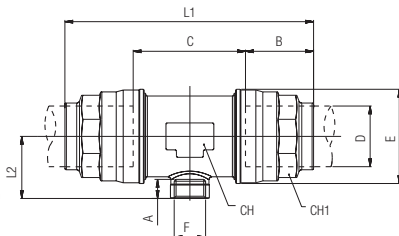

90236 Ø 80-110

СОЕДИНЕНИЕ ПРЯМОЕ С ОТВОДОМ С ВНУТР. РЕЗЬБОЙ

FEMALE FITTING FOR OUTLET

T-ANSCHLUSS MIT INNENGEWINDE

TÉ FILETÉ

RACOR PARA BAJANTE ROSCA HEMBRA

CONEXÃO PARA SAÍDA DE AR (ROSCA FÊMEA)

Код	D	F	A	B	C	E	L1	L2	CH	CH1	Упак.
90236 00 009	80	3/4	14.5	91	109	145	291.5	138	6	42	1
90236 00 010	80	1"	17	91	109	145	291.5	138	6	49	1
90236 00 011	80	1"-1/2	20	91	109	145	291.5	138	6	66	1
90236 00 012	80	2"	22	91	109	145	291.5	138	6	80	1
90236 00 013	110	3/4	14.5	125.5	150.5	200	401	180	8	42	1
90236 00 014	110	1"	17	125.5	150.5	200	401	180	8	49	1
90236 00 015	110	1"-1/2	20	125.5	150.5	200	401	180	8	66	1
90236 00 016	110	2"	22	125.5	150.5	200	401	180	8	80	1

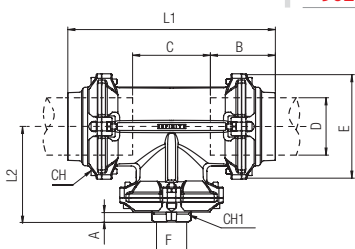

90237

NPTF

СОЕДИНЕНИЕ ПРОХОДНОЕ С ОТВОДОМ С ВН. РЕЗЬБОЙ

FEMALE FITTING FOR OUTLET
T-ANSCHLUSS MIT INNENGEWINDE
TÉ FILETÉ
RACOR PARA BAJANTE ROSCA HEMBRA
CONEXÃO PARA SAÍDA DE AR (ROSCA FÊMEA)

Код	D	F(NPTF)	A	B	C	E	L1	L2	CH	CH1	Упак.
90237 00 007	20	1/2	13.5	31.5	48	34.5	109	25	28	30	3
Алюминий - Aluminium - Aluminium - Aluminium - Aluminio - Alumínio											
90237 00 017 A	63	1/2	13.5	57.5	88	94	203	53	80	75	1
90237 00 005 A	63	3/4	14	57.5	88	94	203	54	80	75	1
90237 00 018 A	63	1"	17	57.5	88	94	203	56.5	80	75	1

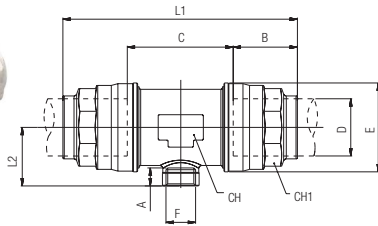

90237 Ø 110

NPTF

СОЕДИНЕНИЕ ПРОХОДНОЕ С ОТВОДОМ С ВН. РЕЗЬБОЙ

FEMALE FITTING FOR OUTLET
T-ANSCHLUSS MIT INNENGEWINDE
TÉ FILETÉ
RACOR PARA BAJANTE ROSCA HEMBRA
CONEXÃO PARA SAÍDA DE AR (ROSCA FÊMEA)

Код	D	F(NPTF)	A	B	C	E	L1	L2	CH	CH1	Упак.
90237 00 013	110	3/4	14	125.5	150.5	200	401	180	8	42	1
90237 00 014	110	1"	17	125.5	150.5	200	401	180	8	49	1
90237 00 015	110	1 1/2"	17.5	125.5	150.5	200	401	180	8	66	1
90237 00 016	110	2"	17.5	125.5	150.5	200	401	180	8	80	1

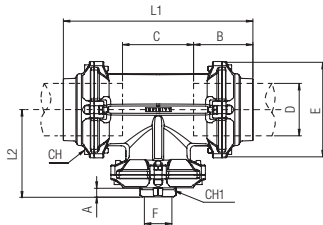

Функция

RU

Данный фитинг является альтернативой крутоизогнутому отводу по трудоемкости монтажа, эффективная внутренняя система обеспечивает поступление воздуха в отвод без конденсата, который остается в магистральном трубопроводе и сливается через штатное устройство.

Function

GB

This fitting is a valid alternative to the traditional swan-neck; it shows itself as a quicker and cost effective solution. The efficient internal system allows to the air to reach the usage points without any condense which stays within the main circuit and than it can be drained in the most convenient point.

Funktion

DE

Diese Verschraubung ist eine echte Alternative zum traditionellen Schwanenhals, zeigt sich jedoch als eine schnellere und wirtschaftlichere Lösung. Das effizient wirksame interne System erlaubt der Luft zu den Abgängen zu gelangen, ohne jegliches Kondenswasser, welches in der Hauptleitung verbleibt und an der geeigneten Stelle entleert werden kann.

Exécutions

FR

Ce raccord est une alternative au col de cygne traditionnel. Il se monte rapidement et est économique. Le système efficace interne ne réduit pas le passage de l'air et permet la rétention des condensats dans le système principal afin d'être purgé à un endroit propice.

Funcionamiento

ES

Este racor es una alternativa válida al tradicional cuello de cisne, y se demuestra una solución más rápida y económica. El eficaz sistema interno, permite el uso del aire sin ningún tipo de condensados, el cuál permanece en la línea principal y puede ser drenado en el punto más conveniente.

Funcionamento

PT

Esta conexão é uma opção para o tradicional sistema de pescoço de ganso; e apresenta-se como uma solução bem mais rápida e econômica. Este sistema é extremamente eficaz e permite que o ar chegue ao ponto de utilização sem a presença do condensado, que é mantido na tubulação principal de forma a ser drenado em um ponto mais conveniente.

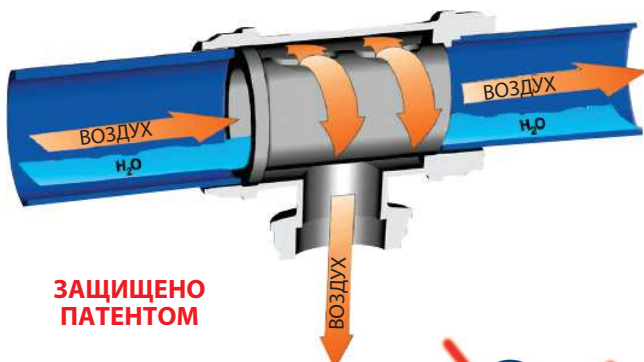

ЗАЩИЩЕНО ПАТЕНТОМ

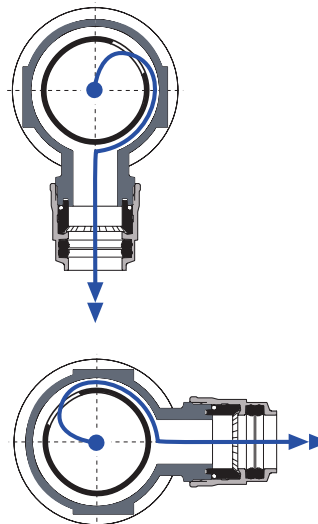

90240

НАКЛАДНОЙ ОТВОД ВРЕЗКИ

SADDLE CLAMP CONNECTOR
SCHNELLFLANSCH REDUZIERT
BRIDE DE DÉRIVATION POSE
RAPIDE BRIDA PARA BAJANTE
FLANGE PARA SAÍDA DE AR

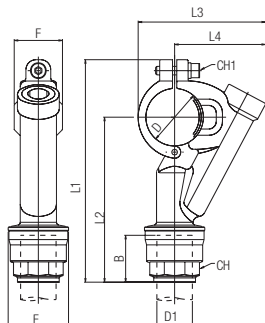

Код	D	D1	B	E	F	L1	L2	L3	L4	CH	CH1	Упак.
90240 00 003	32	20	31.5	34.5	34	136.5	100.5	78	57	30	5	6
90240 00 004	32	25	38.5	42.5	34	144.5	108.5	78	57	35	5	6
90240 00 005	40	20	31.5	34.5	34	148.5	108	89.5	64	30	5	4
90240 00 006	40	25	38.5	42.5	34	156.5	116	89.5	64	35	5	4
90240 00 007	50	20	31.5	34.5	42.5	167.5	118.5	105.5	74	30	6	2
90240 00 008	50	25	38.5	42.5	42.5	175.5	126.5	105.5	74	35	6	1
90240 00 010	63	20	31.5	34.5	42.5	185	130	119	81	30	6	1
90240 00 011	63	25	38.5	42.5	42.5	193	138	119	81	35	6	1

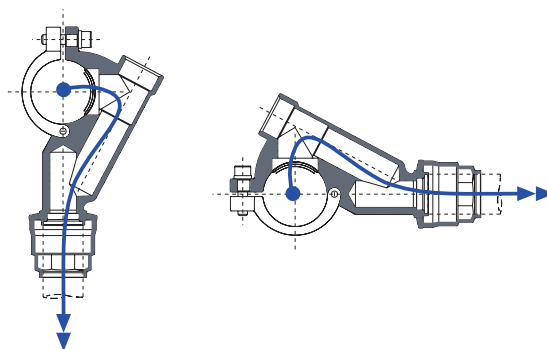

90246

НАКЛАДНОЙ АДАПТЕР ВРЕЗКИ С ВНУТР. РЕЗЬБОЙ

FEMALE SADDLE CLAMP CONNECTOR
SCHNELLFLANSCH MIT INNENGEWINDE
BRIDE TARAUDÉE
RACOR PARA BAJANTE ROSCA HEMBRA
FLANGE PARA SAÍDA DE AR (ROSCA FÊMEA)

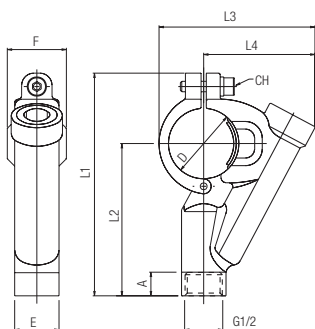

Код	D	A	E	F	L1	L2	L3	L4	CH	Упак.
90246 00 003	32	1/2	13	25.5	34	115	79	78	57	2
90246 00 004	40	1/2	13	25.5	34	125.5	85	89.5	64	2
90246 00 005	50	1/2	13	25.5	42.5	144.5	95.5	105.5	74	2
90246 00 006	63	1/2	13	25.5	42.5	162	107	119	81	1

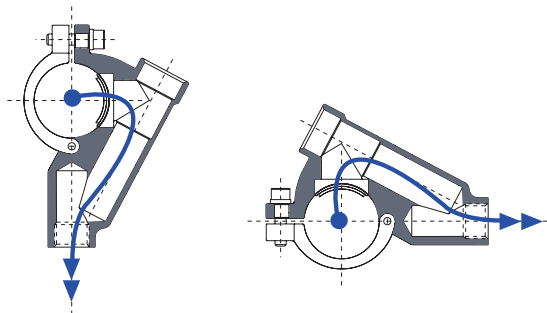

90247

НАКЛАДНОЙ АДАПТЕР ВРЕЗКИ С ВНУТР. РЕЗЬБОЙ

FEMALE SADDLE CLAMP CONNECTOR
SCHNELLFLANSCH MIT INNENGEWINDE
BRIDE TARAUDÉE
RACOR PARA BAJANTE ROSCA HEMBRA
FLANGE PARA SAÍDA DE AR (ROSCA FÊMEA)

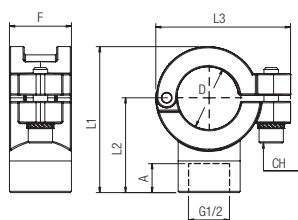

Код	D	A	F	L1	L2	L3	CH	Упак.
90247 00 002	25	1/2	15	25.5	50	39	55.5	2
90247 00 003	32	1/2	15	34	63.5	42.5	61.5	2
90247 00 004	40	1/2	15	34	71	46	70	2
90247 00 005	50	1/2	15	42.5	83.5	52	84.5	2
90247 00 006	63	1/2	15	42.5	95.5	57.5	97	1

90247 Ø 80-110

АДАПТЕР ВРЕЗКИ НАКЛАДНОЙ С ВНУТР. РЕЗЬБОЙ

FEMALE SADDLE CLAMP CONNECTOR
SCHNELLFLANSCH MIT INNENGEWINDE
BRIDE TARAUDÉE
RACOR PARA BAJANTE ROSCA HEMBRA
FLANGE PARA SAÍDA DE AR (ROSCA FÊMEA)

Код	D	B	A	F	L1	L2	L3	CH	Упак.
90247 00 007	80	3/4	16.5	50	117.5	66.5	141.5	6	1
90247 00 008	80	1"	19	50	120	69	141.5	6	1
90247 00 009	110	3/4	16.5	50	152.5	82	189.5	8	1
90247 00 010	110	1"	19	50	155	84.5	189.5	8	1

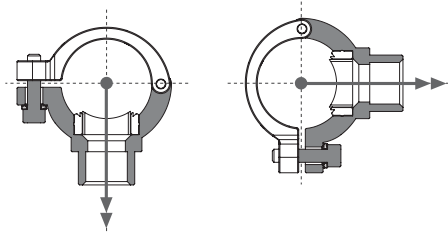
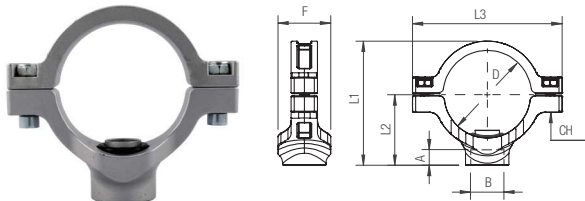

90248

NPTF

АДАПТЕР ВРЕЗКИ НАКЛАДНОЙ С ВНУТР. РЕЗЬБОЙ

FEMALE SADDLE CLAMP CONNECTOR
SCHNELLFLANSCH MIT INNENGEWINDE
BRIDE TARAUDÉE
RACOR PARA BAJANTE ROSCA HEMBRA
FLANGE PARA SAÍDA DE AR (ROSCA FÊMEA)

Код	D	(NPTF)	A	F	L1	L2	L3	CH	Упак.
90248 00 002	25	1/2	13.5	25.5	50	39	55.5	5	2
90248 00 003	32	1/2	13.5	34	63.5	42.5	61.5	5	2
90248 00 004	40	1/2	13.5	34	71	46	70	5	2
90248 00 005	50	1/2	13.5	42.5	83.5	52	84.5	6	1
90248 00 006	63	1/2	13.5	42.5	95.5	57.5	97	6	1

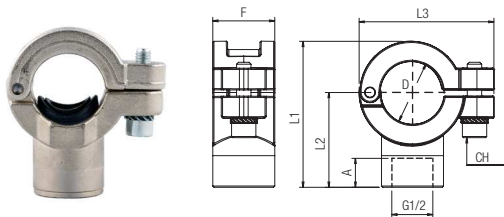

90241

ФРЕЗА ДЛЯ ВРЕЗКИ В ПОД НАКЛАДНОЙ АДАПТЕР

TOOL FOR SADDLE CLAMP CONNECTOR

BOHRER FÜR SCHNELLFLANSCH

OUTIL DE PERCAGE

FRESA PARA BRIDA PARA BAJANTE

FRESA PARA PERFURAÇÃO DE TUBOS PARA CRIAÇÃO DE SAÍDA DE AR

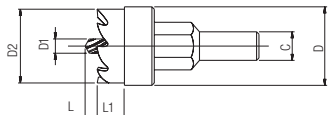

Код	Труба	C	D	D1	D2	L	L1	Упак.
90241 00 003	25	9	17.5	6	17	3	10	1
90241 00 001	32 - 40 - 80 - 110	9	24	6	23.5	3	10	1
90241 00 002	50 - 63	9	31	6	30.5	3	9	1

90242

КОНДУКТОР ДЛЯ ВРЕЗКИ В ТРУБОПРОВОД

DRILLING JIG

BOHRSCHABLONE

GABARIT DE PERCAGE

ÚTIL PARA TALADRO DEL TUBO

SUPORTE PARA GUIAR FURAÇÃO

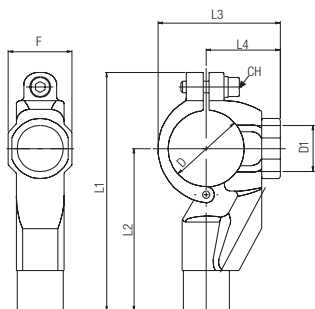

Код	D	D1	F	L1	L2	L3	L4	CH	Упак.
90242 00 001	32	24.5	34	115	79	56	35	5	1
90242 00 002	40	24.5	34	127	86.5	65	39.5	5	1
90242 00 003	50	32	42.5	146	97	79	47.5	6	1
90242 00 004	63	32	42.5	163.5	108.5	93	55	6	1

90249

КОНДУКТОР ДЛЯ ВРЕЗКИ В ТРУБОПРОВОД

DRILLING JIG

BOHRSCHABLONE

GABARIT DE PERCAGE

BRIDA DE BAJANTE HEMBRA

SUPORTE PARA GUIAR FURAÇÃO

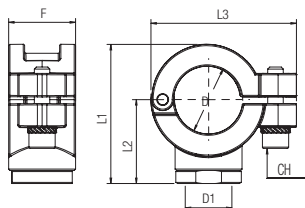

Код	D	D1	F	L1	L2	L3	CH	Упак.
90249 00 002	25	17.8	25.5	53	32	55.5	5	1
90249 00 003	32	24.5	34	56	35	61.5	5	1
90249 00 004	40	24.5	34	65	40	70	5	1
90249 00 005	50	32	42.5	79	47.5	84.5	6	1
90249 00 006	63	32	42.5	93	55	97	6	1

90249 Ø 80-110

КОНДУКТОР ДЛЯ ВРЕЗКИ В ТРУБОПРОВОД

DRILLING JIG

BOHRSCHABLONE

GABARIT DE PERCAGE

BRIDA DE BAJANTE HEMBRA

SUPORTE PARA GUIAR FURAÇÃO

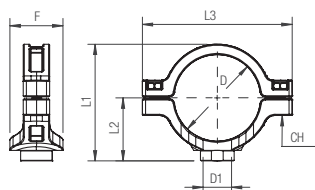

Код	D	D1	F	L1	L2	L3	CH	Упак.
90249 00 007	80	24.5	50	110.5	59.5	141.5	6	1
90249 00 008	110	24.5	50	135.5	64.5	189.5	8	1

Инструкция по накладным фитингам RU

Накладные фитинги обеспечивают новую врезку без демонтажа участков трубопровода.

- 1 Сбросьте давление в системе.
- 2 Установите кондуктор № арт 90242 на точку врезки. Убедитесь, что канал кондуктора вертикален к оси отвода. Для облегчения позиционирования кондуктора вложите в него кусок трубы диаметра 20 мм.
- 3 Выполните врезку фрезой № арт. 90241.

Instructions de montage bride FR

Les brides permettent d'installer de nouvelles dérivations sur un réseau existant sans démonter les tubes.

- 1 Dépressuriser.
- 2 Placez le gabarit de perçage art. 90242 sur le tube à l'emplacement souhaité. Assurez-vous que le trou de guidage est perpendiculaire à l'axe de descente. Pour faciliter le positionnement du gabarit, insérer un tube de diamètre Ø20 mm.
- 3 Percez le tube avec l'outil art. 90241.

Mounting instructions flange GB

Saddle clamp allows to set up a new drop in an existing system without removing tubes.

- 1 Depressurization.
- 2 Mount art. 90242 on tube wherever necessary. Be careful that jig bore must intersect the axis of tube drop. It is possible to connect a tube diameter Ø 20 to take easier the positioning of the drilling jig.
- 3 Drill the tube with proper tool art. 90241.

Instrucciones de instalación ES

La brida para bajante permite realizar un nuevo bajante en una instalación ya terminada sin tener que mover la misma. Para su instalación seguir las siguientes instrucciones.

- 1 Despresurización de la línea.
- 2 Posicionar el art. 90242 centrador sobre el tubo en el punto deseado. El taladro de guía del útil debe ser perpendicular al eje del tubo. Es posible insertar un tubo de Ø20 para facilitar el posicionamiento del tubo.
- 3 Taladrar el tubo con la fresa art. 90241.

Montageanleitung DE

Die Schnellflansche ermöglichen einen neuen Abgang zu erstellen, ohne dass das Leitungsnetz demontiert werden muss.

- 1 Drucklos.
- 2 Positionieren Sie die Bohrschablone Art. 90242 auf dem Rohr an die gewünschte Stelle. Stellen Sie sicher, dass das Führungsloch senkrecht zur Achse des Abganges ist. Um die Positionierung der Schablone zu erleichtern, legen Sie ein Rohr von Ø20mm Durchmesser ein.
- 3 Bohren des Rohres mit dem Bohrer Art. 90241.

Instruções de montagem PT

A flange para saída de ar permite se criar uma nova saída em uma tubulação existente sem necessidade de remoção dos tubos.

- 1 Depressurização.
- 2 Posicione a peça cód. 90242 no ponto desejado da tubulação. Assegure-se que a guia de furação esteja perpendicular ao eixo de saída. Caso deseje, engate um tubo para facilitar o posicionamento da guia.
- 3 Fure o tubo utilizando a fresa cód. 90241

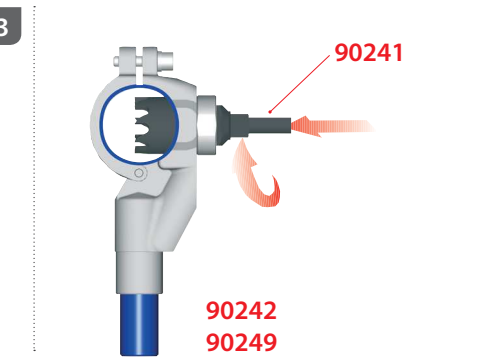
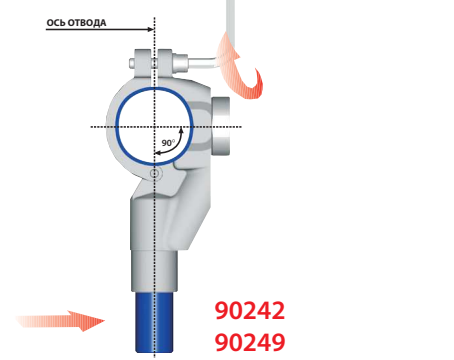
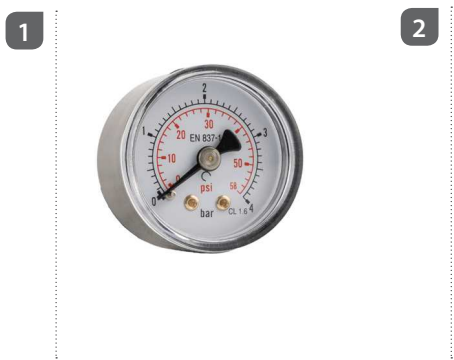

- 4 Осторожно - не просверлите трубу насквозь.
- 5 Демонтируйте кондуктор № арт. 90242 и зачистите отверстие от заусенцев.
- 6 Установите накладной отвод № арт. 90240. Убедитесь в правильной позиции уплотнения и затяните крепеж.

- 4 Do not damage the tube.
- 5 Take down art. 90242 and remove residual material
- 6 Mount and tighten art. 90240. Be careful that lipseal lays into the hole correctly. Screw up.

- 4 Beschädigen Sie nicht die andere Seite des Rohres.
- 5 Demontieren Sie die Bohrschablone Art. 90242 und entfernen Späne und entgraten die Bohrung.
- 6 Montieren Sie den Schnellflansch Art. 90240. Stellen Sie sicher, dass die Dichtung richtig positioniert ist und ziehen Sie die Schraube an.

- 4 Ne pas endommager l'autre coté du tube.
- 5 Démontez le gabarit art. 90242, enlever les copeaux et ébavurer.
- 6 Monter la bride art. 90240. Vérifier que le joint est bien positionné et serrer.

- 4 Prestar atención en no dañar la pared opuesta del tubo.
- 5 Desmontar el art. 90242 y eliminar los eventuales residuos de materiales.
- 6 Montar y apretar el art. 90240 de forma que el labio de la junta de estanqueidad se introduzca correctamente en el taladro realizado. Apretar el tornillo para completar el montaje.

- 4 Tenha cuidado para não danificar o outro lado do tubo durante a furação.
- 5 Desmonte a guia cód. 90242 e remova eventuais resíduos presentes na tubulação.
- 6 Monte e parafuse a conexão cód. 90240. Assegure-se que a vedação entre corretamente no furo. Aperte o parafuso.

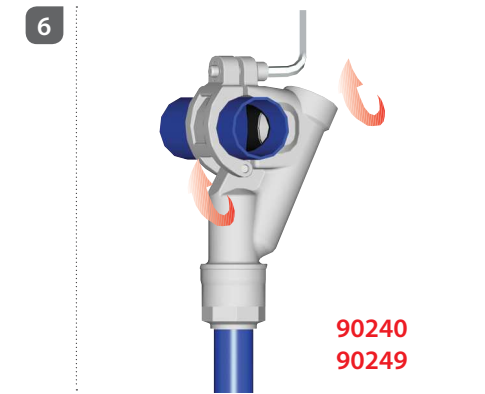
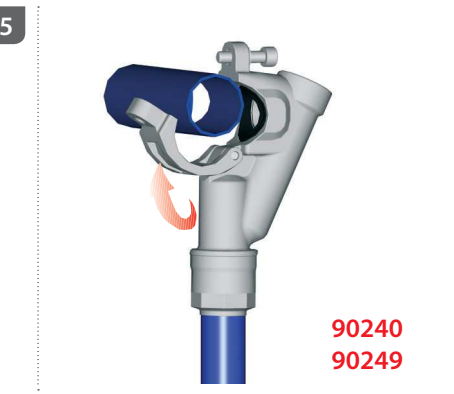
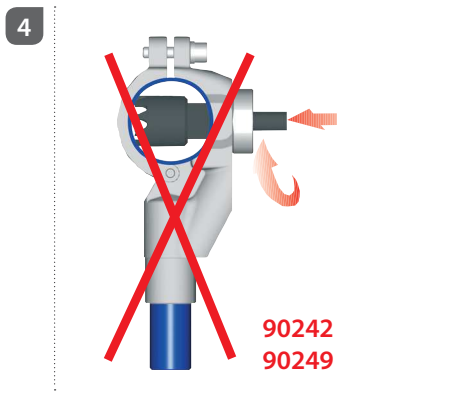

90252

ИНСТРУМЕНТ ДЛЯ СВЕРЛЕНИЯ ТРУБ INFINITY

DRILLING TOOL FOR INFINITY TUBES
BOHRWERKZEUG FÜR INFINITY ROHR
OUTIL PERÇAGE TUBES
HERRAMIENTA DE PERFORACION
FERRAMENTA DE PERFURAÇÃO



Код	Размеры	Упак.
90252 00 001	25-32-40-50-63	1

90253

ОТВОД НАКЛАДНОЙ С АРМАТУРОЙ

SADDLE CLAMP CONNECTOR WITH VALVE
SCHNELLFLANSCH MIT INNENGEWINDE U. KUGELHAHN
BRIDE DE DESCENTE AVEC ROBINET
BRIDA PARA BAJANTE HEMBRE CON VALVULA
FLAGE PARA SAIDA DE AR CON ROSCA FEMEA E VÁLVULA DE BÓIA

Код	D	F	L1	L2	L3	CH1	CH2	Упак.	
90253 00 002	25	1/2	25.5	161	97.5	55.5	5	25	1
90253 00 003	32	1/2	34	168	104	61.5	5	25	1
90253 00 004	40	1/2	34	176	112	70	5	25	1
90253 00 005	50	1/2	42.5	188	125	84.5	6	25	1
90253 00 006	63	1/2	42.5	200	137	97	6	25	1

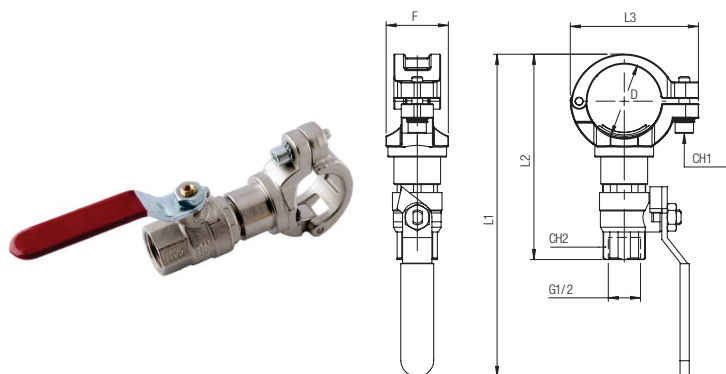

Монтаж фитинга № арт. 90253

RU

- 1 Установите накладной фитинг № арт. 90253 на трубу и затяните крепеж – откройте шаровой кран.
- 2 Закрепите инструмент для сверления № арт. 90252 на шаровом кране и затяните его.
- 3 Присоедините дрель к инструменту и сверлите до упора.
- 4 Отсоедините дрель от инструмента и ответдите назад вал инструмента; закройте шаровой кран и снимите инструмент с крана.

Mounting instructions flange 90253

GB

- 1 Mount the saddle clamp Art.90253 on tube and screw it carefully – open the valve.
- 2 Mount the drilling tool Art.90252 on valve and screw it carefully.
- 3 Mount the drill on the drilling tool Art.90252 and drill the tube till the stop.
- 4 Remove the drill and pull back the drill tip; close the valve before removing the drilling tool.

Montageanleitung 90253

DE

- 1 Positionieren Sie den Schnellflansch Art. 90253 auf dem Rohr und ziehen den Flansch an – öffnen Sie den Kugelhahn.
- 2 Befestigen Sie das Bohrwerkzeug Art. 90252 auf dem Kugelhahn und ziehen es richtig an.
- 3 Befestigen Sie die Bohrmaschine auf dem Bohrwerkzeug und bohren bis zum Anschlag in das Rohr.
- 4 Entfernen Sie die Bohrmaschine vom Bohrwerkzeug und schieben den Bohrer ganz zurück; schliessen Sie den Kugelhahn und entfernen das Bohrwerkzeug aus dem Kugelhahn.

Instructions de montage bride code 90253

FR

- 1 Positionner la bride réf. 90253 sur le tube et visser la vis de fixation. Ouvrir la vanne à bille.
- 2 Visser l'outil de perçage réf. 90252 sur la vanne à bille.
- 3 Fixer la perceuse sur l'outil réf. 90252 et percer jusqu'à venir en butée.
- 4 Retirer la perceuse (mèche) et fermer la vanne à bille. Démontar la perceuse puis l'outil de perçage.

Instrucciones de instalación 90253

ES

- 1 Posicionar el art. 90253 sobre el tubo en el punto deseado. Abrir la válvula.
- 2 Montar el art. 90252 en la válvula. Atornille con cuidado.
- 3 Montar la broca sobre el art. 90252 y taladrar el tubo hasta el fondo.
- 4 Retirar la broca. Cierrar la válvula antes que destmontar el art. 90252.

Instruções de montagem 90253

PT

- 1 Montar art. 90253 no tubo. Enroscar cuidadosamente. Abrir a válvula.
- 2 Montar art. 90252 na válvula. Enroscar cuidadosamente.
- 3 Montar a broca de perfuração no art. 90252 e perfurar o tubo até o fim.
- 4 Retirar a broca. Feche a válvula antes de retirar el art. 90252.

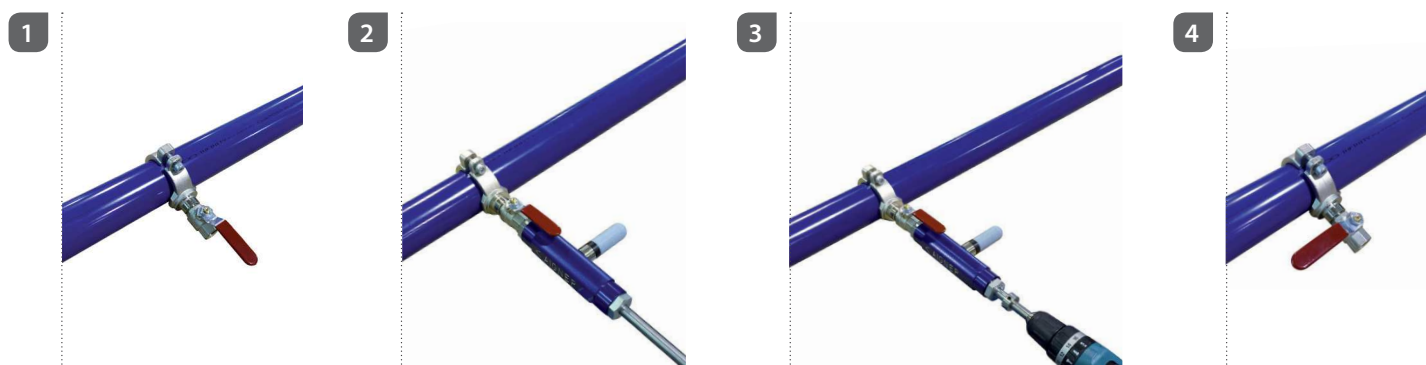

90610

ЗАГЛУШКА

PLUG
VERSCHLUSSZAPFEN
BOUCHON
TAPÓN
TAMPÃO

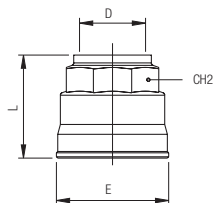

Код	D	L	E	CH2	Упак.
90610 00 001	20	33	34.5	30	10
90610 00 002	25	39	42.5	35	6
90610 00 003	32	46.5	52	45	4
90610 00 004	40	53	63	55	4
90610 00 005	50	62	73	65	2
Алюминий - Aluminium - Aluminium - Aluminium - Aluminium - Alumínio					
90610 00 006 A	63	64	94	75	1

90610 - Ø 80-110

ЗАГЛУШКА

PLUG
VERSCHLUSSZAPFEN
BOUCHON
TAPÓN
TAMPÃO

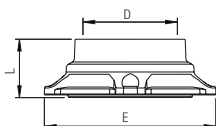

Код	D	L	E	Упак.
90610 00 007	80	49.5	145	1
90610 00 008	110	68	200	1

90620

РЕДУКЦИЯ ПРЯМАЯ

REDUCER
REDUZIERUNG
RÉDUCTION
REDUCCIÓN
REDUÇÃO

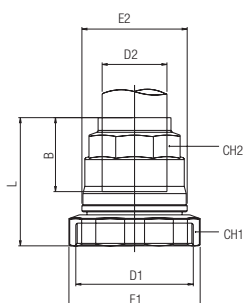

Код	D1	D2	B	E1	E2	L	CH1	CH2	Упак.
90620 00 001	25	20	31.5	43.5	34.5	48	42	30	5
90620 00 002	32	20	31.5	54	34.5	48.5	52	30	5
90620 00 003	32	25	38.5	54	42.5	55	52	35	5
90620 00 004	40	20	31.5	65	34.5	50	63	30	4
90620 00 005	40	25	38.5	65	42.5	56.5	63	35	4
90620 00 006	40	32	46	65	52	63.5	63	45	3
90620 00 011	50	25	38.5	75	42.5	55	73	35	1
90620 00 007	50	32	46	75	52	63.5	73	45	1
90620 00 008	50	40	52	75	63	69	73	55	1
90620 00 009 A	63	40	52	95	63	84.5	92	55	1
90620 00 010 A	63	50	63.5	95	73	92.5	92	65	1

Монтаж 90620

IT

- 1 Снимите гайку
- 2 Смонтируйте № арт. 90620

Assembling 90620

GB

- 1 Remove the nut
- 2 Mount art. 90620

Montageanleitung 90620

DE

- 1 Entfernen sie die Mutter
- 2 Montieren art. 90620

Assemblage 90240

FR

- 1 Démontez l'écrou
- 2 Montez art. 90620

Montaje 90620

ES

- 1 Quitar la tuerca
- 2 Montar 90620

Montagem 90620

PT

- 1 Remover a porca
- 2 Montar cód. 90620

1



2



90625

ПЕРЕХОДНОЙ АДАПТЕР С ВНУТРЕННЕЙ РЕЗЬБОЙ

FEMALE REDUCER
 AUFSCHRAUBVERSCHRAUBUNG
 ADAPTATEUR FEMELLE
 ADAPTADOR HEMBRA
 REDUÇÃO COM ROSCA FÊMEA

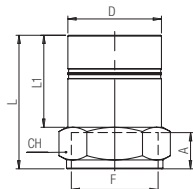

Код	D	F	A	L	L1	CH	Упак.
Алюминий - Aluminium - Aluminium - Aluminium - Aluminio - Aluminio							
90625 00 011 A	63	1"1/2	20	84	62	65	2
90625 00 012 A	63	2"	22	90	62	65	2

90626

NPTF

ПЕРЕХОДНОЙ АДАПТЕР С ВНУТРЕННЕЙ РЕЗЬБОЙ

FEMALE REDUCER
 AUFSCHRAUBVERSCHRAUBUNG
 ADAPTATEUR FEMELLE
 ADAPTADOR HEMBRA
 REDUÇÃO COM ROSCA FÊMEA

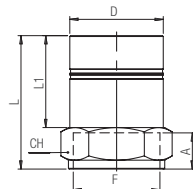

Код	D	F (NPTF)	A	L	L1	CH	Упак.
90626 00 01 CJ NT	20	1/2	13.5	55	35	27	2

90627

ПЕРЕХОДНОЙ АДАПТЕР С НАРУЖНОЙ РЕЗЬБОЙ

MALE REDUCER
 EINSCHRAUBVERSCHRAUBUNG
 ADAPTATEUR MÂLE
 ADAPTADOR MACHO
 REDUÇÃO COM ROSCA MACHO

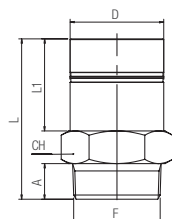

Код	D	F	A	L	L1	CH	Упак.
Алюминий - Aluminium - Aluminium - Aluminium - Aluminio - Aluminio							
90627 00 012 A	63	2"	24	108	62	65	2

90628

NPTF

ПЕРЕХОДНОЙ АДАПТЕР С НАРУЖНОЙ РЕЗЬБОЙ

MALE REDUCER
EINSCHRAUBVERSCHRAUBUNG
ADAPTATEUR MÂLE
ADAPTADOR MACHO
REDUÇÃO COM ROSCA MACHO

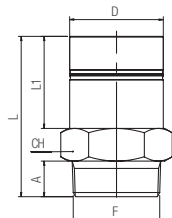

Код	D	F (NPTF)	A	L	L1	CH	Упак.
90628 00 01 CJ NT	20	1/2	17	59	35	22	2
90628 00 01 DH NT	20	3/4	17.5	60.5	35	27	2
90628 00 01 NF NT	25	1/2	17	67	42	27	2
90628 00 01 3I NT	25	3/4	17.5	67.5	42	27	2
90628 00 01 DL NT	25	1"	21.5	73.5	42	34	2
90628 00 01 4I NT	32	1"	21.5	83.5	52	34	1
90628 00 01 F7 NT	32	1"1/2	23	89.5	52	50	1
90628 00 01 NE NT	40	1"1/2	23	93	55.5	50	1
90628 00 01 6I NT	50	1"1/2	23	106	68.5	55	1
90628 00 01 G5 NT	50	2"	23.5	112	68.5	65	1
90628 00 01 7I NT	63	2"	23.5	125.5	82	65	1
90628 00 01 58 NT	63	2"1/2	35	139	82	75	1

90630

ПЕРЕХОДНЫЙ АДАПТЕР С ВНУТРЕННЕЙ РЕЗЬБОЙ

FEMALE REDUCER
REDUZIERUNG INNENGEWINDE
RÉDUCTION FILETÉE
REDUCCIÓN HEMBRA
REDUÇÃO FÊMEA

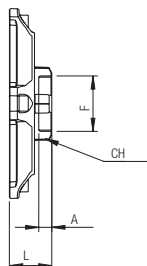

Код	Труба	F	A	L	CH	Упак.
90630 00 005	80	3/4	14.5	42	42	1
90630 00 006	80	1"	17	42	49	1
90630 00 007	80	1"-1/2	20	42	66	1
90630 00 008	80	2"	22	42	80	1
90630 00 001	110	3/4	14.5	48	42	1
90630 00 002	110	1"	17	48	49	1
90630 00 003	110	1"-1/2	20	48	66	1
90630 00 004	110	2"	22	48	80	1

90631

NPTF

ПЕРЕХОДНЫЙ АДАПТЕР С ВНУТРЕННЕЙ РЕЗЬБОЙ

FEMALE REDUCER
REDUZIERUNG INNENGEWINDE
RÉDUCTION FILETÉE
REDUCCIÓN HEMBRA
REDUÇÃO FÊMEA

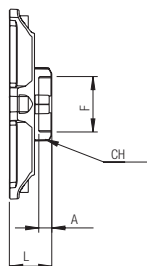

Код	Труба	F (NPTF)	A	L	CH	Упак.
90631 00 005	80	3/4	14	48	42	1
90631 00 006	80	1"	17	48	49	1
90631 00 007	80	1"1/2	17.5	48	66	1
90631 00 008	80	2"	17.5	48	80	1
90631 00 001	110	3/4	14	42	42	1
90631 00 002	110	1"	17	42	49	1
90631 00 003	110	1"1/2	17.5	42	66	1
90631 00 004	110	2"	17.5	42	80	1

90642

ПОДКЛЮЧЕНИЕ НАСТЕННОЕ НА 2 ПОРТА

2 WAYS MANIFOLD
WANDANSCHLUSS 2-FACH
PRISE MURALE FILETÉE, 2 SORTIES
REPARTIDOR 2 SALIDAS
SAÍDA DE AR DUPLA

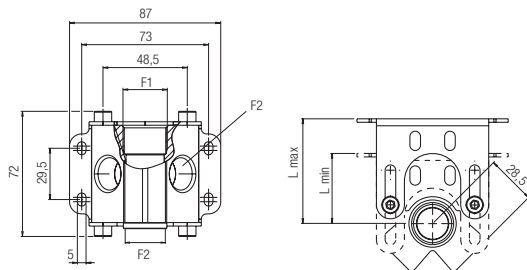

Код	F1	F2	n°	Lmax	Lmin	Упак.
90642 00 001	1/2	1/2	2	60	35	1
90642 00 002	3/4	1/2	2	60	35	1

90643

NPTF

ПОДКЛЮЧЕНИЕ НАСТЕННОЕ НА 2 ПОРТА

2 WAYS MANIFOLD
WANDANSCHLUSS 2-FACH
PRISE MURALE FILETÉE, 2 SORTIES
REPARTIDOR 2 SALIDAS
SAÍDA DE AR DUPLA

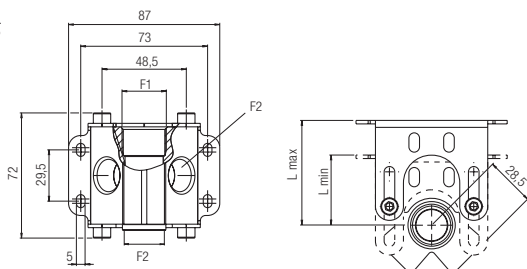

Код	F1 (NPTF)	F2 (NPTF)	n°	Lmax	Lmin	Упак.
90643 00 001	1/2	1/2	2	60	35	1
90643 00 002	3/4	1/2	2	60	35	1

ПРИМЕРЫ ПРИМЕНЕНИЯ - APPLICATIONS EXEMPLE - BEISPIELE FÜR ANWENDUNGEN
EXEMPLES D'APPLICATIONS - EJEMPLO DE APLICACIÓN - EXEMPLOS DE APLICAÇÕES

90642
90010
661



90642
90720
661



90642
90010
6310
661



90642
90720
6310
661



90642
90010
6310
191

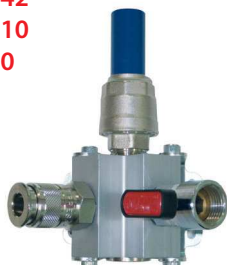

90642
90720
6310
191



90642
90010
191



90642
90720
191



90642
90010
2060
T100
661



90644

ПОДКЛЮЧЕНИЕ НАСТЕННОЕ НА 4 ПОРТА

4 WAYS MANIFOLD
WANDANSCHLUSS 4-FACH
PRISE MURALE FILETÉE, 4 SORTIES
REPARTIDOR 4 SALIDAS
SAÍDA DE AR QUADRUPLA

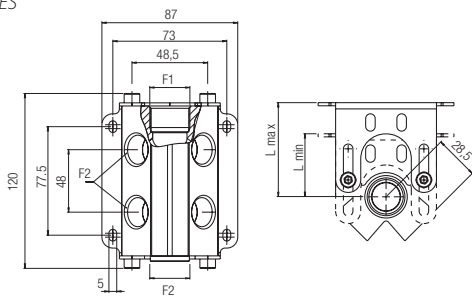

Код	F1	F2	n°	Lmax	Lmin	Упак.
90644 00 001	1/2	1/2	4	60	35	1
90644 00 002	3/4	1/2	4	60	35	1

90645

NPTF

ПОДКЛЮЧЕНИЕ НАСТЕННОЕ НА 4 ПОРТА

4 WAYS MANIFOLD
WANDANSCHLUSS 4-FACH
PRISE MURALE FILETÉE, 4 SORTIES
REPARTIDOR 4 SALIDAS
SAÍDA DE AR QUADRUPLA

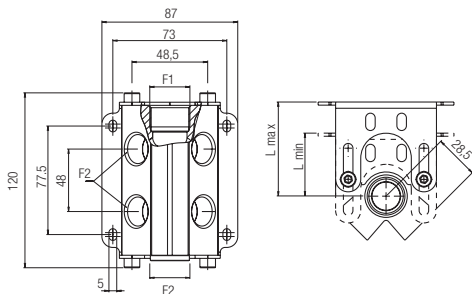

Код	F1 (NPTF)	F2 (NPTF)	n°	Lmax	Lmin	Упак.
90645 00 001	1/2	1/2	4	60	35	1
90645 00 002	3/4	1/2	4	60	35	1

ПРИМЕРЫ ПРИМЕНЕНИЯ - APPLICATIONS EXAMPLE - BEISPIELE FÜR ANWENDUNGEN
EXEMPLES D'APPLICATIONS - EJEMPLO DE APLICACIÓN - EXEMPLOS DE APLICAÇÕES

90644
90010
661



90644
90720
661



90644
90010
6310
661



90644
90010
6310
661



90644
90010
6310
661



90644
90720
191



90644
90010
6310
191



90644
90720
6310
191



90644
90010
2060
T100
661



90600

НАСТЕННОЕ ПОДКЛЮЧЕНИЕ ПОВОРОТНОЕ

BRACKET FITTING - ADJUSTABLE
 WANDANSCHLUSS 1-FACH - EINSTELLBAR
 PRISE MURALE, 1 SORTIE FEMELLE - ORIENTABLE
 RACOR CODO A FIJACIÓN 1 SALIDA
 SAÍDA DE AR DUPLA - ORIENTÁVEL

Код	D	F	B	C	E	L1	L2	L3	Lmax	Lmin	CH1	CH2	Упак.
90600 00 001	20	1/2	31.5	19.5	34.5	35	51	35	40	22	21	30	4
90600 00 002	25	3/4	38.5	23	42.5	37	62	39	40	22	26	35	3
90600 00 003	32	1"	46	28	52	41	74.5	48.5	40	26	34	45	2

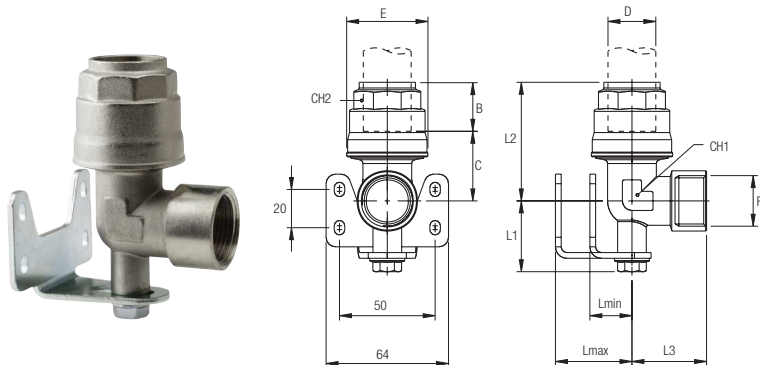

90601

NPTF

НАСТЕННОЕ ПОДКЛЮЧЕНИЕ ПОВОРОТНОЕ

BRACKET FITTING - ADJUSTABLE
 WANDANSCHLUSS 1-FACH - EINSTELLBAR
 PRISE MURALE, 1 SORTIE FEMELLE - ORIENTABLE
 RACOR CODO A FIJACIÓN 1 SALIDA
 SAÍDA DE AR DUPLA - ORIENTÁVEL

Код	D	F (NPTF)	B	C	E	L1	L2	L3	Lmax	Lmin	CH1	CH2	Упак.
90601 00 001	20	1/2	31.5	19.5	34.5	35	51	35	40	22	21	30	4
90601 00 002	25	1/2	38.5	23	42.5	37	62	39	40	22	26	35	3
90601 00 003	32	1/2	46	28	62	41	74.5	48.5	40	26	34	45	2

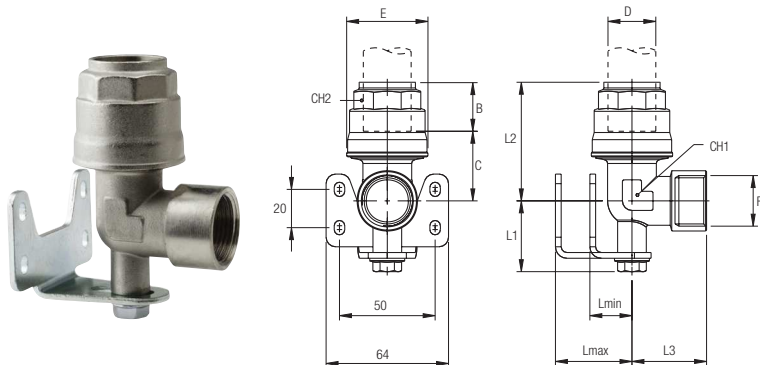

90602

НАСТЕННОЕ ПОДКЛЮЧЕНИЕ НА 2 ПОРТА ПОВОРОТНОЕ

2 WAYS MANIFOLD - ADJUSTABLE
 WANDANSCHLUSS 2-FACH - EINSTELLBAR
 PRISE MURALE, 2 SORTIES FEMELLES - ORIENTABLE
 REPARTIDOR 2 SALIDAS AJUSTABLE
 SAÍDA DE AR DUPLA - ORIENTÁVEL

Код	D	F	B	C	E	I	L1	L2	Lmin	Lmax	CH1	CH2	Упак.
90602 00 001	20	1/2	31.5	20	34.5	28.5	27	51.5	22	54	26	30	2
90602 00 002	25	1/2	38.5	21	42.5	28.5	27	59	22	54	26	35	2

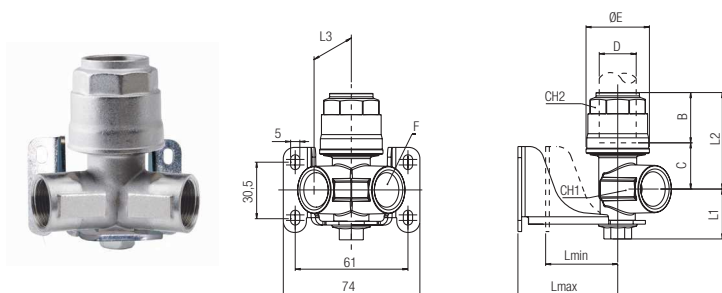

90603

NPTF

ПОДКЛЮЧЕНИЕ НАСТЕННОЕ НА 2 ПОРТА, ПОВОРОТНОЕ

2 WAYS MANIFOLD - ADJUSTABLE
 WANDANSCHLUSS 2-FACH - EINSTELLBAR
 PRISE MURALE, 2 SORTIES FEMELLES - ORIENTABLE
 REPARTIDOR 2 SALIDAS AJUSTABLE
 SAÍDA DE AR DUPLA - ORIENTÁVEL

Код	D	F (NPTF)	B	C	E	I	L1	L2	Lmin	Lmax	CH1	CH2	Упак.
90603 00 001	20	1/2	31.5	20	34.5	28.5	27	51.5	22	54	26	30	2
90603 00 002	25	1/2	38.5	21	42.5	28.5	27	59	22	54	26	35	2

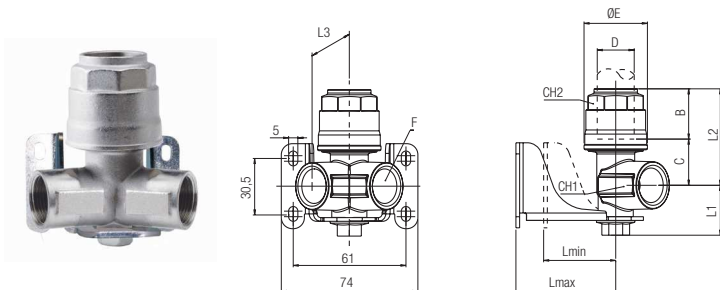

90660

ПОДКЛЮЧЕНИЕ НАСТЕННОЕ НАКЛОННОЕ, НА 2 ПОРТА С ВНУТРЕННЕЙ РЕЗЬБОЙ

2 WAYS INCLINED MANIFOLD TUBE-FEMALE
 WANDANSCHLUSS 2-FACH MIT ROHRANSCHLUSS 45°
 PRISE MURALE, 2 SORTIES FEMELLES 45°
 REPARTIDOR A 2 VÍAS INCLINADO CONEXIÓN TUBO-HEMбра
 SAÍDA DE AR DUPLA INCLINADA TUBO-ROSCA FÊMEA

Код	D	F	B	C	E	L1	L2	L3	Lmin	Lmax	CH	Упак.
90660 00 001	20	1/2	31.5	34.5	34.5	31	66	37.5	22	54	30	2
90660 00 002	25	1/2	38.5	33	42.5	31	71.5	37.5	22	54	35	2

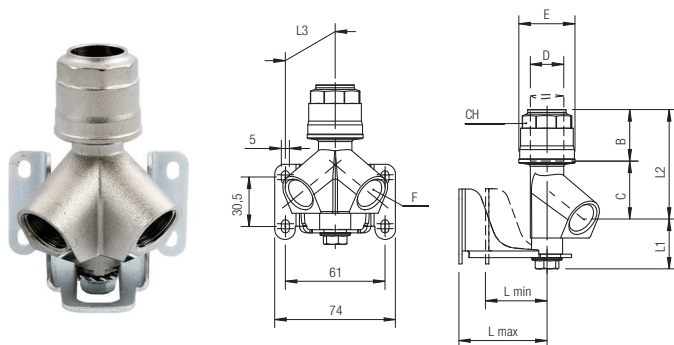

90661

NPTF

ПОДКЛЮЧЕНИЕ НАСТЕННОЕ НАКЛОННОЕ, НА 2 ПОРТА С ВНУТРЕННЕЙ РЕЗЬБОЙ

2 WAYS INCLINED MANIFOLD TUBE-FEMALE
 WANDANSCHLUSS 2-FACH MIT ROHRANSCHLUSS 45°
 PRISE MURALE, 2 SORTIES FEMELLES 45°
 REPARTIDOR A 2 VÍAS INCLINADO CONEXIÓN TUBO-HEMбра
 SAÍDA DE AR DUPLA INCLINADA TUBO-ROSCA FÊMEA

Код	D	F (NPTF)	B	C	E	L1	L2	L3	Lmin	Lmax	CH	Упак.
90661 00 001	20	1/2	31.5	34.5	34.5	31	66	37.5	22	54	30	2
90661 00 002	25	1/2	38.5	33	42.5	31	71.5	37.5	22	54	35	2

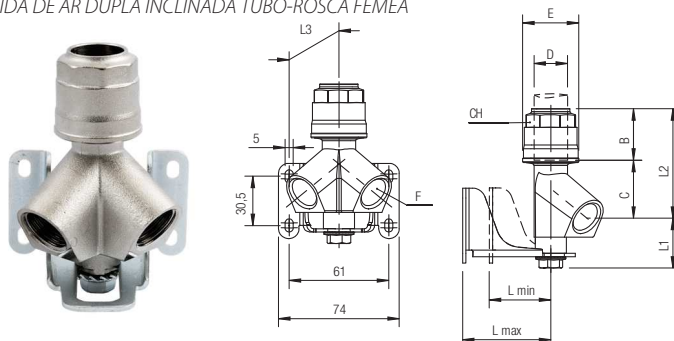

90662

ПОДКЛЮЧЕНИЕ НАСТЕННОЕ НАКЛОННОЕ, НА 2 ПОРТА С ВНУТРЕННЕЙ РЕЗЬБОЙ

2 WAYS INCLINED MANIFOLD FEMALE
 WANDANSCHLUSS 2-FACH MIT INNENGEWINDE 45°
 PRISE MURALE, 2 SORTIES TARAUDÉES 45°
 REPARTIDOR A 2 VÍAS INCLINADO CONEXIÓN HEMBRA
 SAÍDA DE AR DUPLA INCLINADA ROSCA FÊMEA

Код	A	F	B	E	L1	L2	L3	L _{min}	L _{max}	Упак.
90662 00 001	1/2	1/2	13	32	31	40.5	37.5	22	54	2
90662 00 002	3/4	1/2	16.5	32	31	39	37.5	22	54	2

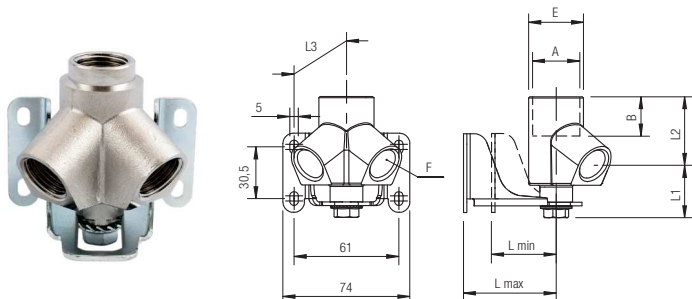

90663

NPTF

ПОДКЛЮЧЕНИЕ НАСТЕННОЕ НАКЛОННОЕ, НА 2 ПОРТА С ВНУТРЕННЕЙ РЕЗЬБОЙ

2 WAYS INCLINED MANIFOLD FEMALE
 WANDANSCHLUSS 2-FACH MIT INNENGEWINDE 45°
 PRISE MURALE, 2 SORTIES TARAUDÉES 45°
 REPARTIDOR A 2 VÍAS INCLINADO CONEXIÓN HEMBRA
 SAÍDA DE AR DUPLA INCLINADA ROSCA FÊMEA

Код	A (NPTF)	F (NPTF)	B	E	L1	L2	L3	L _{min}	L _{max}	Упак.
90663 00 001	1/2	1/2	13.5	32	31	40.5	37.5	22	54	2
90663 00 002	3/4	1/2	14	32	31	39	37.5	22	54	2

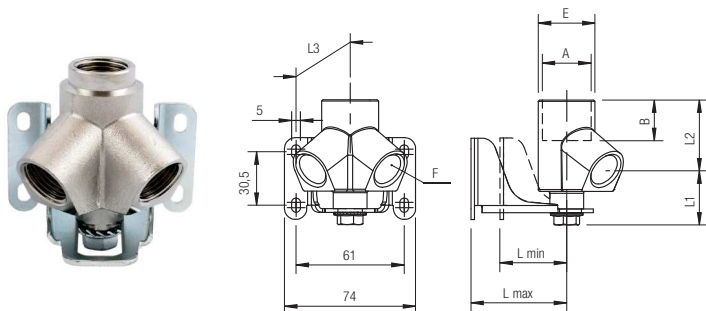

90664

ПОДКЛЮЧЕНИЕ НАСТЕННОЕ НАКЛОННОЕ, НА 2 ПОРТА С ВНУТРЕННЕЙ РЕЗЬБОЙ И АРМАТУРОЙ

2 WAYS INCLINED MANIFOLD VALVE-FEMALE
 WANDANSCHLUSS 2-FACH 45° MIT MONTIERTEM KUGELHAHN
 PRISE MURALE, 2 SORTIES FEMELLES 45°, AVEC ROBINET
 REPARTIDOR A 2 VÍAS INCLINADO CONEXIÓN HEMBRA
 SAÍDA DE AR DUPLA INCLINADA ROSCA FÊMEA COM VÁLVULA ACOPLADA

Код	D	F	B	E	L1	L2	L3	L4	L5	L _{min}	L _{max}	CH	Упак.
90664 00 001	20	1/2	31.5	34.5	31	40.5	37.5	84.5	184	22	54	30	2
90664 00 002	25	1/2	38.5	42.5	31	39	37.5	101.5	209	22	54	35	2

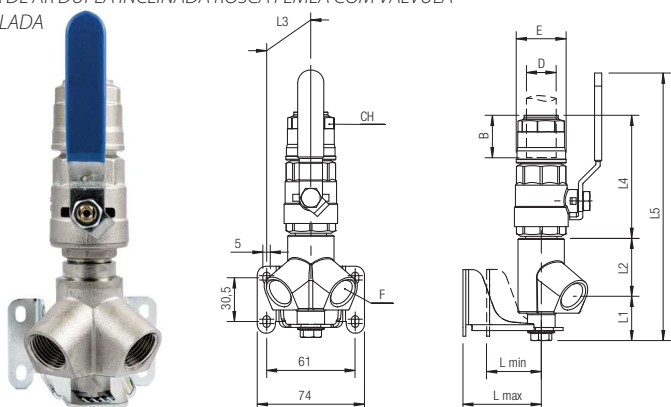

90665

NPTF

RIPARTITORE 2 VIE INCLINATO CON VALVOLA - FEMMINA

2 WAYS INCLINED MANIFOLD VALVE-FEMALE

WANDANSCHLUSS 2-FACH 45° MIT MONTIERTEM KUGELHAHN

PRISE MURALE, 2 SORTIES FEMELLES 45°, AVEC ROBINET

REPARTIDOR A 2 VÍAS INCLINADO CONEXIÓN HEMBRA

SAÍDA DE AR DUPLA INCLINADA ROSCA FÊMEA COM VÁLVULA ACOPLADA

Код	D	F (NPTF)	B	E	L1	L2	L3	L4	L5	L _{min}	L _{max}	CH	Упак.
90665 00 001	20	1/2	31.5	34.5	31	40.5	37.5	84.5	184	22	54	30	2
90665 00 002	25	1/2	38.5	42.5	31	39	37.5	101.5	209	22	54	35	2

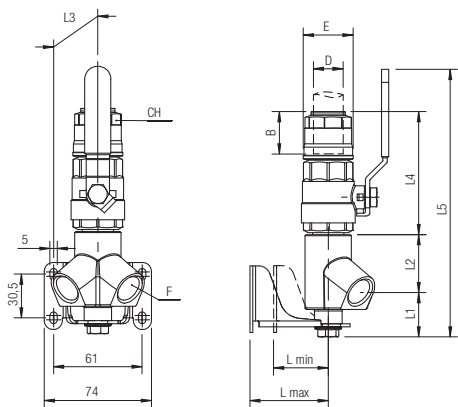

90700

КРАН ШАРОВОЙ ПОЛНОПРОХОДНОЙ

BALL VALVE TUBE/TUBE

KUGELHAHN - VOLLER DURCHGANG

ROBINET DOUBLE EGAL - PLEIN PASSAGE

VÁLVULA DE BOLA A 2 VÍAS TUBO/TUBO

VÁLVULA DE ESFERA

Код	D	(DN)	B	C	E	L	CH1	CH2	G	H	Упак.
90700 00 001	20	17	31.5	58.5	34.5	121.5	32	30	88	42	2
90700 00 002	25	22	38.5	61.5	42.5	138.5	41	35	106	47.5	2
90700 00 003	32	29	46	75	52	167	50	45	106	53	2
90700 00 004	40	37	52.5	81	63	186	59	55	134	65	1
90700 00 005	50	46	63.5	103	73	230	69	65	134	72.5	1
Алюминий - Aluminium - Aluminium - Aluminium - Aluminio - Aluminio											
90700 00 006 A	63	59	57.5	126	94	232	89	75	240	111.5	1

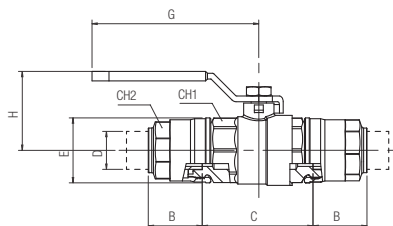

90705

КРАН ШАРОВОЙ ПОЛНОПРОХОДНОЙ С ЗАМКОМ

BALL VALVE TUBE/TUBE WITH PADLOCK
 KUGELHAHN - VOLLER DURCHGANG INKL. VORHÄNGESCHLOSS
 ROBINET DOUBLE EGAL - PLEIN PASSAGE INCL. CADENAS
 VÁLVULA DE BOLA A 2 VÍAS TUBO/TUBO CANDADO INCLUIDO
 VÁLVULA DE ESFERA CADEADO INCLUSO

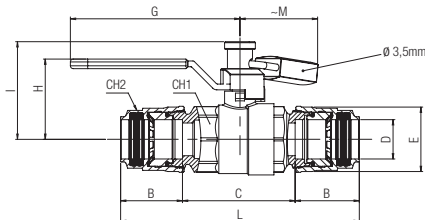

Код	D	DN	B	C	E	L	CH1	CH2	G	H	I	M	Упак.
90705 00 001	20	17	31.5	58.5	34.5	121.5	32	30	88	42	50.7	45	2
90705 00 002	25	22	38.5	61.5	42.5	138.5	41	35	106	47.5	59.5	45	2
90705 00 003	32	29	46	75	52	167	50	45	106	53	65	45	2
90705 00 004	40	37	52.5	81	63	186	59	55	134	65	74.5	47	1
90705 00 005	50	46	63.5	103	73	230	69	65	134	72.5	82	47	1

90710

ЗАТВОР ДИСКОВЫЙ ПОВОРОТНЫЙ С КРЕПЕЖОМ

BUTTERFLY VALVE + SCREWS + NUTS + WASHERS
 ABSPERKLAPPE + SCHRAUBEN + MUTTERN + SCHEIBEN
 VANNE A PAPILLON + VIS + ECROU + RONDELLES
 VÁLVULA MARIPOSA + TORNILLOS + TUERCAS +
 ARANDELAS VÁLVULA BORBOLETA + PARAFUSOS + PORCAS +
 ARRUELAS

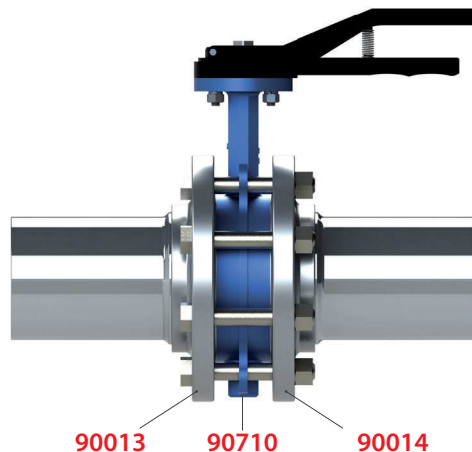
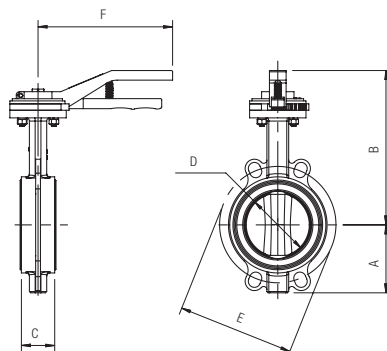

Код	D	DN	A	B	C	E	F	Упак.
90710 00 002	80	77	87	216	46	160	265	1
90710 00 001	110	100	106	201	52	180	265	1

90720

КРАН ШАРОВОЙ КОНЦЕВОЙ С НАРУЖНОЙ РЕЗЬБОЙ

MALE-TUBE BALL VALVE
 KUGELHAHN AUSSENGEWINDE-ROHR
 VANNE TUBE / FILETAGE
 VÁLVULA DE BOLA A 2 VÍAS MACHO-TUBO
 VÁLVULA DE ESFERA ROSCA MACHO-TUBO

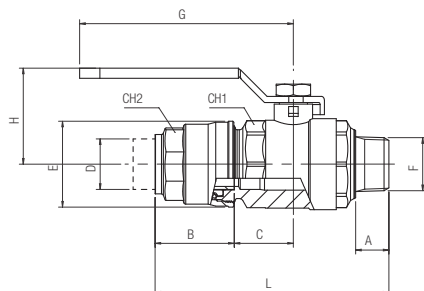

Код	D	F	DN	A	B	C	E	L	CH1	CH2	G	H	Упак.
90720 00 001	20	1/2	15	18	31.5	29.3	34.5	100.8	32	30	88	42	2
90720 00 002	25	3/4	20	18	38.5	30.8	42.5	119.3	41	35	106	47.5	2

90721

NPTF

КРАН ШАРОВОЙ КОНЦЕВОЙ С НАРУЖНОЙ РЕЗЬБОЙ

MALE-TUBE BALL VALVE
KUGELHAHN AUSSERGEWINDE-ROHR
VANNE TUBE / FILETAGE
VÁLVULA DE BOLA A 2 VÍAS MACHO-TUBO
VÁLVULA DE ESFERA ROSCA MACHO-TUBO

Код	D	F (NPTF)	DN	A	B	C	E	L	CH1	CH2	G	H	Упак.
90721 00 001	20	1/2	15	17	31.5	29.3	34.5	100.8	32	30	88	42	2
90721 00 002	25	3/4	20	17.5	38.5	30.8	42.5	119.3	41	35	106	47.5	2

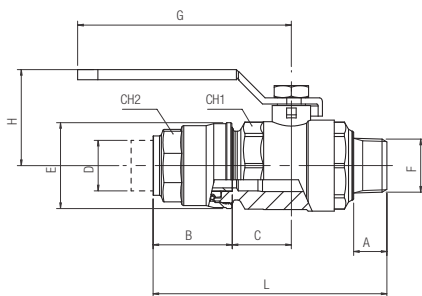

90725

КРАН ШАРОВОЙ КОНЦЕВОЙ С НАРУЖНОЙ РЕЗЬБОЙ И ЗАМКОМ

MALE-TUBE BALL VALVE WITH PADLOCK
KUGELHAHN AUSSERGEWINDE-ROHR INKL. VORHÄNGESCHLOSS
VANNE TUBE / FILETAGE INCL. CADENAS
VÁLVULA DE BOLA A 2 VÍAS MACHO-TUBO CANDADO
INCLUIDO VÁLVULA DE ESFERA R
OSCA MACHO-TUBO CADEADO INCLUSO

Код	D	F	DN	A	B	C	E	L	CH1	CH2	G	H	I	M	Упак.
90725 00 001	20	1/2	15	18	31.5	29.3	34.5	100.8	32	30	88	42	50.7	45	2
90725 00 002	25	3/4	20	18	38.5	30.8	42.5	119.3	41	35	106	47.5	59.5	45	2

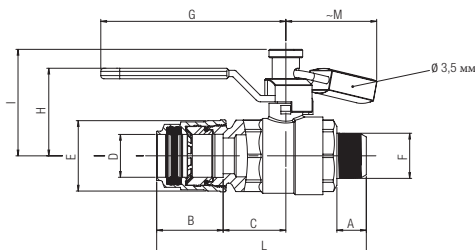

90726

NPTF

КРАН ШАРОВОЙ КОНЦЕВОЙ С НАРУЖНОЙ РЕЗЬБОЙ И ЗАМКОМ

MALE-TUBE BALL VALVE WITH PADLOCK
KUGELHAHN AUSSERGEWINDE-ROHR INKL. VORHÄNGESCHLOSS
VANNE TUBE / FILETAGE INCL. CADENAS
VÁLVULA DE BOLA A 2 VÍAS MACHO-TUBO CANDADO INCLUIDO
VÁLVULA DE ESFERA ROSCA MACHO-TUBO CADEADO INCLUSO

Код	D	F (NPTF)	DN	A	B	C	E	L	CH1	CH2	G	H	I	M	Упак.
90726 00 001	20	1/2	15	17	31.5	29.3	34.5	100.8	32	30	88	42	50.7	45	2
90726 00 002	25	3/4	20	17.5	38.5	30.8	42.5	119.3	41	35	106	47.5	59.5	45	2

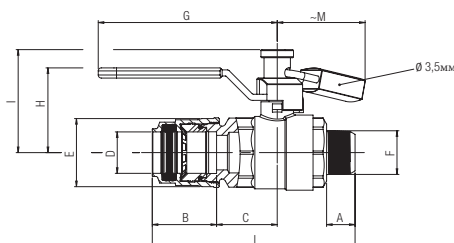

New

КЛАПАН INFINITY

90740

Код	D	Kv	A	B	C	E	F	CH2	Упак.
90740 00 003	32	78	198	46	89	52	92,6	45	1
90740 00 004	40	101	208	52	89	63	92,6	55	1
90740 00 005	50	168	249	63,5	109	73	110	65	1
90740 00 006	63	300	269	57,5	139	94	140,3	75	1



Давление

15 бар (1.5 МПа)

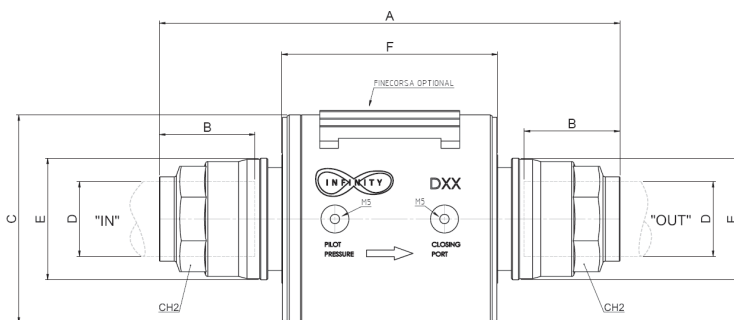

Функция

IT

Клапан является нормально закрытым, при этом открытие и закрытие осуществляются давлением сети.

За отсутствием сети минимального давления 2 бар клапан автоматически переходит из закрытого в открытое состояние. Вентиль полностью открыт при давлении в сети 3,5 бар.

При снижении давления ниже 2 бар клапан закрывается автоматически закрывается. Это минимальное остаточное давление на участках трубопровода, не затронутых аварией.

Давление из сети постоянно подается на выход "Давление управления". При помощи простого пневматического или электропневматического клапана это давление можно подать на порт "Закрыть" для управления по необходимости.

Function

GB

The valve is normally closed and it uses the pipeline pressure to open and close the compressed air flow.

If not piloted, with a min. pressure of 2 bar the valve transits from closed to open position spontaneously. The valve is fully open with pipeline pressure around 3.5 bar.

If pressure drops under 2 bar the valve automatically closes. This is the minimum pressure that remains in pipeline sections not affected by failure.

The pipeline pressure is always available on the outlet "Pilot Pressure". Using a pneumatic or electro-pneumatic deflector is possible to flow this pressure to the "Closing Port" in order to close the valve immediately.

Funktion

DE

Das Ventil ist normalerweise geschlossen, wobei zum Öffnen und Schliessen des Druckluftstroms der Leitungsdruck verwendet wird.

Wenn nicht mit einem Mindestdruck von 2 bar gesteuert, wechselt das Ventil spontan von der geschlossenen in die geöffnete Position. Das Ventil ist vollständig geöffnet bei einem Leitungsdruck um 3,5 bar.

Wenn der Druck unter 2 bar fällt, schliesst das Ventil automatisch. Dies ist der Mindestdruck, der in den Rohrleitungsabschnitten bleibt, welche nicht durch den Ausfall betroffen sind.

Der Leitungsdruck ist immer auf dem Ausgang "Steuerdruck". Durch den Einsatz eines einfachen pneumatischen oder elektro-pneumatischen Schalters, ist es möglich diesen Druck auf den "Closing Port" zu leiten, damit das Ventil sofort schliesst.

Exécutions

FR

La vanne clapet est normalement fermée et exploite la pression dans le conduit pour l'ouverture ou la fermeture du débit d'air.

La vanne, si non pilotée, passe graduellement de la position fermée en position ouverte à une pression minimale de 2 bars et atteint les conditions de plein débit dès que la pression minimale est de 3,5 bars.

Notez que si la pression tombe à 2 bars environs, le clapet se ferme automatiquement. Donc en cas de panne, les parties du réseau non directement concernées par la perte sont maintenues avec une pression minimale égale à cette valeur.

La pression à l'intérieur du tube est toujours disponible à la sortie "pilot pressure". Grâce à un simple dispositif pneumatique ou électro-pneumatique vous pouvez diriger cette pression vers le "closing port" pour obtenir la fermeture immédiate de la vanne.

Funcionamiento

ES

La válvula es normalmente cerrada y utiliza la presión del circuito para abrir y cerrar el flujo de aire comprimido.

Si no está pilotada, con una presión mínima de 2 bar la válvula se abre de inmediato. La válvula estará totalmente abierta cuando la presión llega a los 3,5 bar.

Si la presión cae por debajo de los 2 bar la válvula se cierra automáticamente. Esta es la presión mínima que permanece en las secciones de tubería no afectadas por el fallo.

La presión de la tubería está siempre disponible en la salida de la "presión de pilotaje". Utilizando un deflector neumático o electro-neumático es posible fluir esta presión hacia el cierre en modo de cerrar la válvula inmediatamente.

Funcionamento

PT

A válvula está normalmente fechada e utiliza a pressão da rede para abrir e fechar o fluxo de ar comprimido.

Se não for pilotada com uma pressão mínima de 2 bar, a válvula comuta da posição aberta para a posição fechada espontaneamente. A válvula é completamente aberta com uma pressão de rede de cerca de 3,5 bar.

Se a pressão descer abaixo de 2 bar a válvula automaticamente fecha. Esta é a pressão mínima que permanece em seções da rede não afetadas por falha.

A pressão de rede está sempre disponível na saída "Pilot Pressure" (Pressão Piloto).

Usando um defletor pneumático ou eletro-pneumático é possível direcionar esta pressão para a conexão "Closing Port" (Via de Fechamento), de maneira a fechar a válvula imediatamente.

Закрытый клапан

Closed Valve
Geschlossenes Ventil
Vanne fermée
Válvula cerrada
Válvula fechada

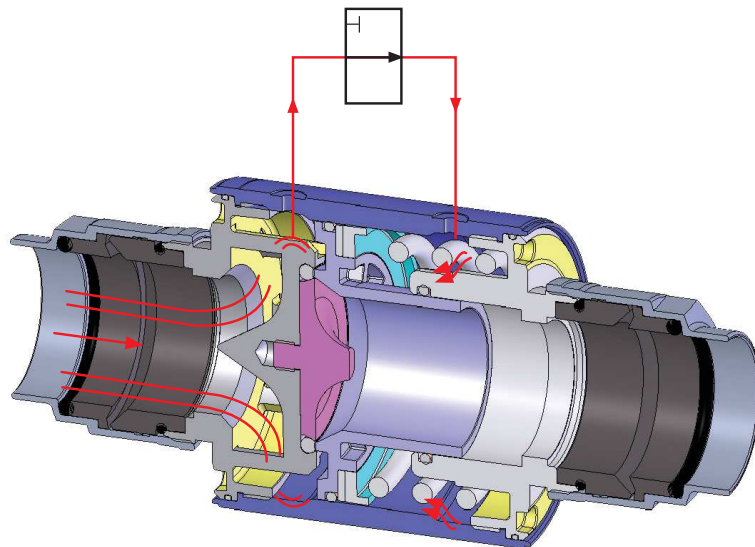

Открытый клапан при давлении в магистрали 2 бар

Open valve with inline pressure higher than 2 bar
Offene Ventile mit einem Inline-Arbeitsdruck höher als 2 bar
Vanne ouverte avec pression en ligne supérieure à 2 bar
Válvula abierta con una presión en la línea superior a 2 bar
Válvula aberta com uma pressão em linha superior a 2 bar

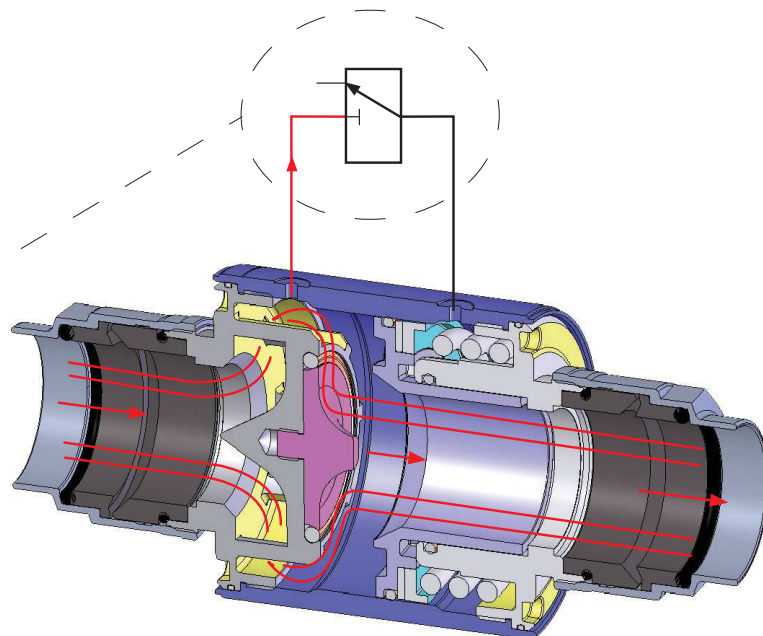

МИКРОКЛАПАН ДЛЯ МОНТАЖА В ПАНЕЛЬ

MICROVALVE FOR PANEL MOUNTING ACTUATOR
STÖSSEL - MIKROVENTIL, SCHALTAFELEINBAU
MICRODISTRIBUTEUR À POUSSOIR, MONTAGE EN PANNEAU
MICROVÁLVULA PARA ACTUADORES DE PANEL
MICRO-VÁLVULA PARA ATUADOR DE PAINEL



МЕХАНИЗМ ПЕРЕКЛЮЧЕНИЯ С КЛЮЧОМ

KEY SELECTOR
SCHLÜSSELSCHALTER
BOUTON TOURNANT, À CLÉ
SELECTOR DE LLAVE
SELETOR COM CHAVE



Код Code Nummer Code Código Código	Схема Ways Wege Voies Vias	Функция Function Funktion Fonction Función Funções	Размер Size Größe Dimension Medida Tamanho	Упак.
02V D0 3 NC B5	3/2	H3	M5	1

Код Code Nummer Code Código Código	Цвет Color Farbe Couleur Cores	Функция Function Funktion Fonction Función Funções	Позиция извлечения ключа Position to pull the key out Schlüsselabnahme Retrait de clé Posición extracción llave Posição de retirada da chave	Упак.
04V 03 0 00 02	■	0 - 1	Ambedue - Both position Beide- Les deux Ambas posiciones - Ambas as posições	1

90790

КОЛЛЕКТОР ПРОХОДНОЙ НА 4 ПОРТА

4 WAYS DISTRIBUTION MANIFOLD

VERTEILERBLOCK 4-FACH

NOURRICE DE DISTRIBUTION 4 SORTIES

REGLETA SIMPLE 4 SALIDAS

DISTRIBUIDOR QUADRUPLA

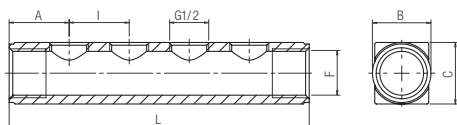

Код	F	A	B	C	L	I	Упак.
90790 00 001	3/4	1/2	25	31	34	164	38 1
90790 00 002	1"	1/2	30	37,5	37	174	38 1
90790 00 003	1"-1/4	1/2	30	47	50	210	50 1

90800

УЧАСТОК ОБХОДА ПРЕПЯТСТВИЙ

"C" TUBE TO AVOID OBSTACLES

VORGEBOGENE ROHRE FORM C

TUBE PRÉ-CINTRÉ EN C

TUBO EVITA OBSTÁCULO "C"

TUBO PARA DESVIO DE OBSTÁCULOS EM "C"

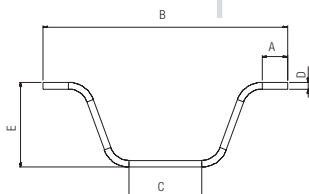

Код	D	A	B	C	E	Упак.
90800 00 11 Y9 B5	20	75	760	254	250	1
90800 00 11 J4 B5	25	75	743	240	250	1

Снят с производства.

Поставки до окончания складских запасов

Until the end stock

Nur solange vorrat

Livable jusqu'à épuisement du stock

Hasta fin de stock

Ate fim do stock

90805

УЧАСТОК ОБХОДА ПРЕПЯТСТВИЙ

"U" TUBE TO AVOID OBSTACLES

VORGEBOGENE ROHRE FORM U

TUBE PRÉ-CINTRÉ EN U

TUBO EVITA OBSTÁCULO "U"

TUBO PARA DESVIO DE OBSTÁCULOS EM "U"

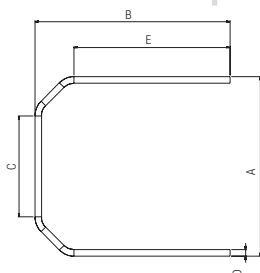
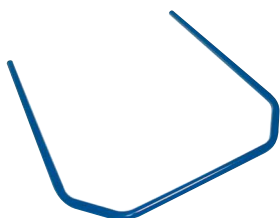

Код	D	A	B	C	E	Упак.
90805 00 11 Y9 B5	20	690	753	394	605	1
90805 00 11 J4 B5	25	690	755	389	604	1
90805 00 11 J9 B5	32	690	773	352	604	1
90805 00 11 K4 B5	40	690	784	289	583	1

Снят с производства.

Поставки до окончания складских запасов

Until the end stock

Nur solange vorrat

Livable jusqu'à épuisement du stock

Hasta fin de stock

Ate fim do stock

90806

Новинка

ГИБКИЙ ШЛАНГ С ДВУСТОРОННИМИ ФИТИНГАМИ

FLEXIBLE HOSE CONNECTED
 FLEXIBLEN SCHLAUCH ANGESCHLOSSEN
 TUBE FLEXIBLE RACCORDE
 MANGUERA FLEXIBLE CONECTADA
 MANGUEIRA FLEXÍVEL CONECTADA

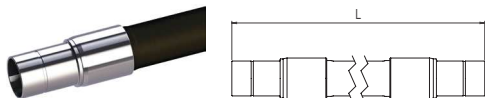

Код	Труба	Длина Lenght Länge Long Longitud Comprimento							Упак.
		Ø	0,75	1	1,5	2	2,5	3	
90806	020	0750	1000	-	2000	-	-	-	1
90806	025	-	1000	-	2000	-	-	-	1
90806	032	-	1000	-	2000	-	3000	-	1
90806	040	-	1000	-	2000	-	3000	-	1
90806	050	-	-	1500	-	2500	-	3500	1
90806	063	-	-	1500	-	2500	-	3500	1



Давление 20 бар (2.0 МПа)



Температура -30 °C
+80 °C

90808

New

КОМПЛЕКТ ПРИВЯЗИ ДЛЯ 90806

SAFETY KIT FOR 90806
 SICHERHEITS-KIT FÜR 90806
 KIT DE SÉCURITÉ POUR 90806
 KIT DE SEGURIDAD PARA 90806
 KIT DE SEGURANÇA PARA 90806



Код	Упак.
90808 00 001	1

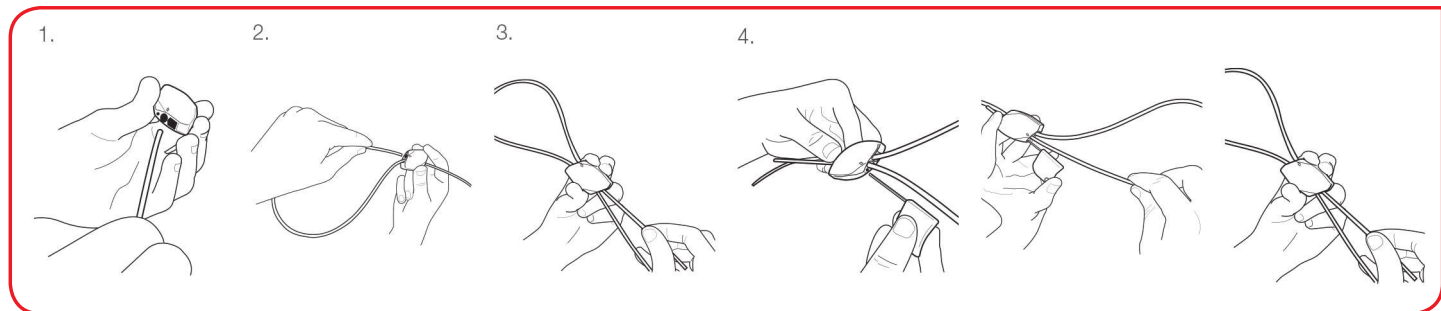

90815

ХОМУТ ИЗ ТЕХНОПОЛИМЕРА С ГАЙКОЙ М6

COLLAR MADE IN TECHNOPOLYMERIC WITH M6 NUT
 ROHRBEFESTIGUNG TECHNOPOLYMER + MUTTER M6
 COLLIER DE FIXATION EN THERMOPLASTIQUE AVEC ECROU M6
 COLLAR EN TECNOPOLIMERO CON TUERCA M6
 SUPORTE TIPO ABRAÇADEIRA EM TECNOPOLÍMERO COM PORCA M6

Код	Труба	A	B	C	Упак.
90815 00 001	20	15	35.5	26	5
90815 00 002	25	17	39.5	26	5
90815 00 003	32	20	44.5	40	5
90815 00 004	40	24.5	53.5	40	5
90815 00 005	50	30	62	54	5
90815 00 006	63	36	73.5	54	5

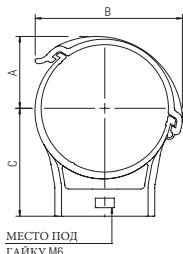

90817

ВСТАВКА КОМПЕНСАЦИИ ДИАМЕТРА ТРУБЫ ДЛЯ ХОМУТА 90815 ИЗ ТЕХНОПОЛИМЕРА

SPACER FOR COLLARS 90815 MADE IN TECHNOPOLYMERIC
 ADAPTER FÜR ROHRBEFESTIGUNG TECHNOPOLYMER 90815
 CALE D'ADAPTATION POUR COLLIER DE FIXATION 90815
 DISTANCIAL PARA COLLAR 90815 EN TECNOPOLÍMERO
 ESPAÇADOR PARA SUPORTE ABRAÇADEIRA 90815 EM TECNOPOLÍMERO

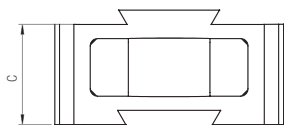

ø20



ø25



ø32



ø40

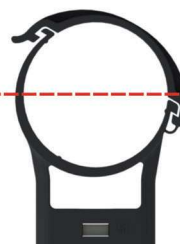

ø50

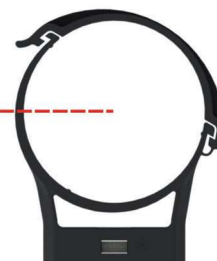

ø63

Код	С	Упак.
90817 00 001	14	5

90820

ХОМУТ СТАЛЬНОЙ

COLLAR MADE IN STEEL
 ROHRBEFESTIGUNG AUS STAHL
 COLLIER DE FIXATION
 COLLAR EN ACERO
 SUPORTE TIPO ABRAÇADEIRA EM AÇO

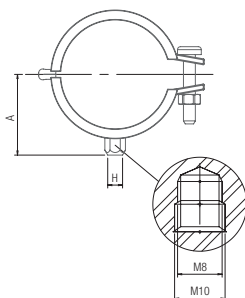

Код	Труба	Н	А	Упак.
90820 00 001	20	M8 / M10	28.5	5
90820 00 002	25	M8 / M10	31	5
90820 00 003	32	M8 / M10	34.5	5
90820 00 004	40	M8 / M10	39.5	5
90820 00 005	50	M8 / M10	44	5
90820 00 006	63	M8 / M10	51	5
90820 00 007	80	M8 / M10	71	4
90820 00 008	110	M8 / M10	81.5	2

РАСПОЛОЖЕНИЕ ХОМУТОВ - COLLAR POSITIONS - POSITIONIERUNG DER BEFESTIGUNGEN POSITIONS DES COLLIERS - POSICIONAMENTO COLLARES - POSICIONAMENTO DOS SUPORTES

Труба 4 м
 4 m Tube
 Rohr 4 m
 Tube 4 m
 Tubo de 4 m
 Tubo de 4 m

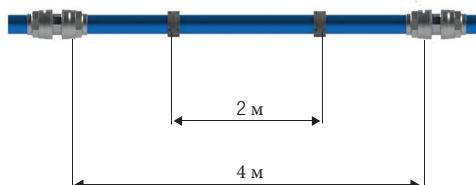

Труба 6 м
 6 m Tube
 Rohr 6 m
 Tube 6 m
 Tubo de 6 m
 Tubo de 6 m

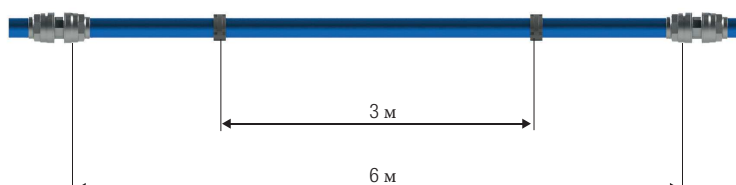

ПНЕВМОШЛАНГ НА КАТУШКЕ

 HOSE REEL
 SCHLAUCHAUFROLLER
 ENROULEURS
 RECOGETUBOS
 MANGUEIRAS

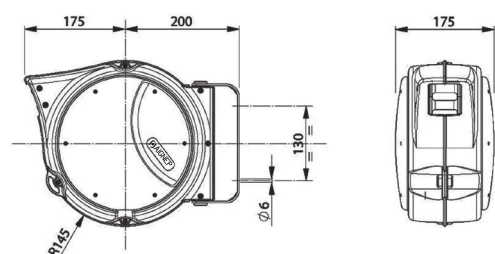
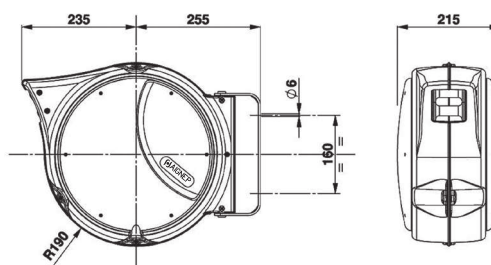
Код: 90825 00 001 9+1

Код: 90825 00 003 15+1

	90825 00 001 9+1	90825 00 003 15+1
Трубка полиуретановая Polyurethane tube Rohr Polyurethan Tube polyuréthane Tubo poliuretano Tubo poliuretano	Ø INT. 8 мм (5/16") Ø EXT. 12 мм	Ø INT. 10 мм Ø EXT. 14 мм
Длина трубки (м) Tube length (m) Rohr Länge (m) Longueur de tube (m) Longitud tubo (m) Comprimento de tubo (m)	9+1	15+1
Максимальное давление Max pressure Max. Druck Pressions maximale Presión máxima Máx. Press.	15 бар (1.5 МПа)	
Температура Temperature Temperatur Température Temperatura Temperatura	- 5 °C + 40 °C	
Выходной фитинг Outlet fitting Anschluss beim Ausgang Raccordement amont Conector de salida Conexão de saída	1/4 наружная	3/8 наружная

	90825 00 001 9+1	90825 00 003 15+1
Входной фитинг Inlet fitting Anschluss beim Eingang Raccordement aval Conector de entrada Conexão de entrada	НЕТ	
Длина входного шланга Cut down size tube Länge des Eingangsröhres Longueur du tube en amont Extremo del tubo Comprimento de entrada	1.5 м	
Воздух Air Luft Air Aire Ar	СИ	
Упаковка Pack. Verp. Cond. Embalaje Embal.	390x330x230 мм 4.5 кг	500x450x255 мм 8.0 кг
Расход при 6 бар 6 bar flow rate Durchflusswert bei 6 bar Débit à 6 bar Caudal a 6 bar Vazão a 6 bar	450 Нл/мин	610 Нл/мин

RU

- Металлическая поворотная скоба
- С запорным устройством для остановки разматывания шланга в нужном положении. Устройство легко демонтируется для обеспечения равномерного натяжения шланга

GB

- Metal swivel fixing bracket
- Automatic device to stop tube at chosen length. This device is easy to disconnect whenever you may need tube in constant traction.

DE

- Drehbarer Metallbügel
- Mit einer Verriegelungsvorrichtung um das Rohr bei der gewünschten Länge zu stoppen. Dieses Gerät kann leicht demontiert werden, um einen gleichmäßigen Zug auf dem Rohr zu haben.

FR

- Embase métallique pivotante
- Equipé d'un dispositif de blocage du tuyau à la longueur souhaitée. Ce dispositif peut être facilement démonté afin d'obtenir une traction constante sur le tuyau.

ES

- Soporte de metal para fijar.
- Dispositivo automático para detener el tubo y elegir el largo

PT

- Suporte de fixação metálico orientável
- Dispositivo automático de parada de tubo na posição desejada. Este dispositivo é facilmente desconectado, quando se necessita do tubo em constante tração.

ПРУЖИНЯЩИЙ ПОДВЕС СО СПИРАЛЬНОЙ ТРУБКОЙ

BALANCER WITH COILED TUBING
 FEDERZUG MIT SPIRALROHR
 ENROULEUR ÉQUILIBREUR AVEC TUBE SPIRALÉ
 BALANCEADOR CON TUBO EN ESPIRAL
 ALACIM CON TUBO ESPIRALADO

Код: 90826

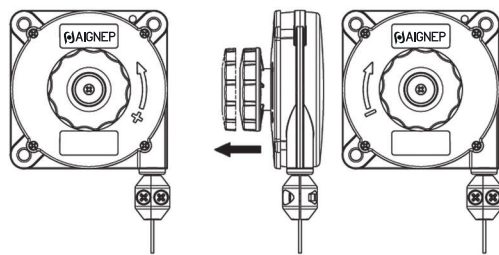
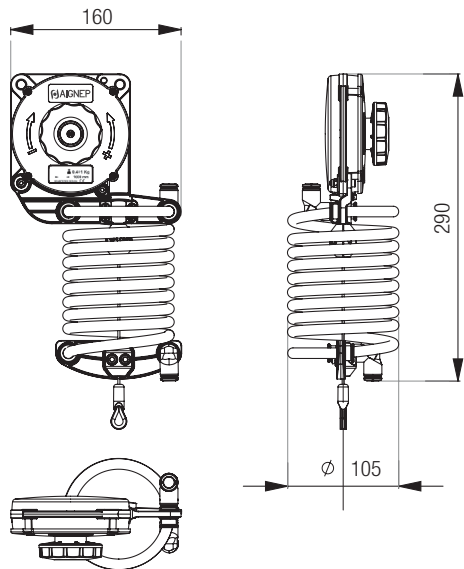

Регулирование нагрузки

Adjusting the load
 Einstellen der Last
 Réglage de la charge
 Ajuste de la carga
 Ajuste da carga

	90826 00 001	90826 00 002	90826 00 003
Нагрузка (кг) Capacity (Kg) Kapazität (Kg) Capacité (Kg) Caudal (Kg) Vazão (Kg)	0.4 ÷ 1	1 ÷ 2	2 ÷ 3
Трос из нерж. стали Stainless steel rope Stahlseil Câble en acier Cable de acero inoxidable Cabo de aço inoxidável		Ø 2 мм	
Длина вытравливания Stroke rope Hublänge Course Longitude cable Largura cabo		1600 мм	
Трубка PA12 Tube Rohr Tube Tubo Tubo		Ø INT. 8мм (5/16") Ø EXT. 10 мм	
Максимальное давление Max pressure Druckbereich max Pressions maximale Presión máxima Máx. Press.		10 бар (1 МПа)	

	90826 00 001	90826 00 002	90826 00 003
Фитинг на входе/выходе Inlet-outlet fitting Anschluss IN/OUT Connexion IN/OUT Conexiones entrada/salida Conexão de saída/entrada		Цанговый фитинг Ø 10 Push-in fitting Ø 10 Steckverschraubungen Ø10 Raccordaje instantané Ø 10 Racordaje automático Ø 10 Conexões Push-in Ø 10	
Входная трубка Cut down size tube Anpassung Adaptable Extremo del tubo Comprimento de entrada		1 м	
Воздух Air Luft Air Aire Ar		SI	
Упаковка Pack. Verp. Cond. Embalaje Embal.		1	

90830

КРОНШТЕЙН
 BRACKET
 HALTERUNGSSCHIEN
 E RAIL DE FIXATION
 SOPORTE
 SUPORTE

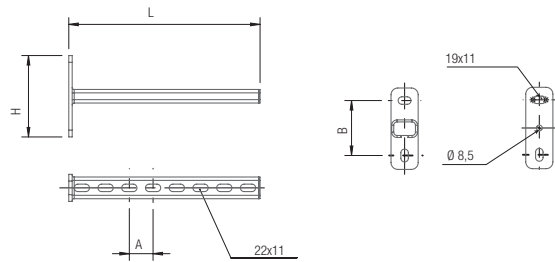

Код	A	B	H	L	Упак.
90830 00 001	35	81	120	280	1

90860

ЗАЖИМ С ОТВЕРСТИЕМ
 CLAMP HANGER
 KLEMMEN MIT BOHRUNG
 PINCE A VISSER
 BRIDA DE SUJECCIÓN (AGUJERO PASANTE)
 SUPORTE DE FIXAÇÃO

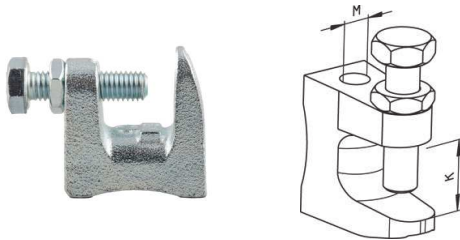

Код	M	K	Упак.
90860 00 001	Ø9	18	5

90861

ЗАЖИМ С РЕЗЬБОЙ
 THREADED CLAMP HANGER
 KLEMMEN MIT GEWINDE
 PINCE A VISSER
 BRIDA DE SUJECCIÓN (AGUJERO ROSCADO)
 SUPORTE DE FIXAÇÃO ROSCADO

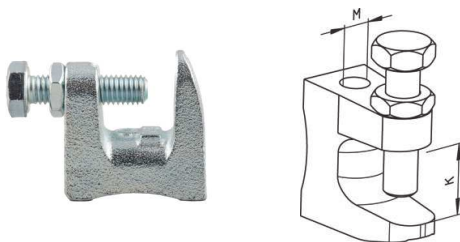

Код	M	K	Упак.
90861 00 001	M8	18	5

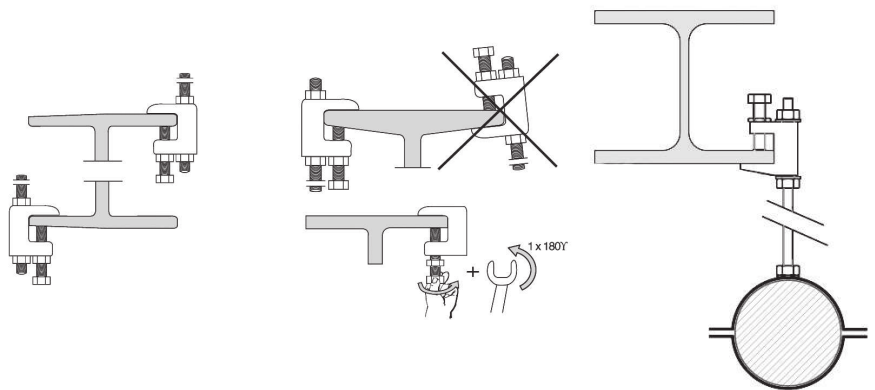

90870

ТРУБОРЕЗ
 PIPE CUTTER
 ROHRABSCHNEIDER
 COUPE-TUBE
 CORTATUBOS
 CORTADOR DE TUBO



Код	Упак.
90870 00 001	20 - 63
90870 00 002	50 - 110
	1
	1

90880

ЗАЧИСТНОЙ ИНСТРУМЕНТ

DE-BURRER
ROHRENTGRATER
OUTIL D'ÉBAVURAGE
DESBARBADOR
DESBASTADOR DE TUBOS



Код	Упак.
90880 00 001	20 - 25 - 32 - 40 1

90885

ИНСТРУМЕНТ ДЛЯ МАРКИРОВКИ ТРУБ

DIMA MARK TUBE
MARKIERUNGSWERKZEUG
GABARIT DE MARQUAGE
MARCATUBO
GUIA PARA CORTE DE TUBO

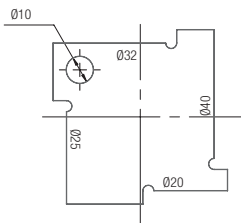

Код	Упак.
90885 00 001	20 - 25 - 32 - 40 1

VAL01

ДЕМОНСТРАЦИОННЫЙ КОМПЛЕКТ

DEMO CASE
DEMONSTRATIONSKOFFER
COFFRE DE DÉMONSTRATION
MALETA EXPOSITOR
MALETA EXPOSITORA



Код	Упак.
VAL01	1

VAL03

КОМПЛЕКТ ИНСТРУМЕНТА INFINITY

TOOLS KIT INFINITY CASE
WERKZEUGKOFFER
COFFRE D'OUTILLAGE
MALETA KIT ÚTILES INFINITY
MALETA FERRAMENTAS



Код	Упак.
VAL03	1

90889

ЭТИКЕТКА САМОКЛЕЯЩАЯСЯ INFINITY ВАКУУМ

LABEL INFINITY VACUUM

AUFKLEBER - VAKUUM

ETIQUETA VACIO

ETIQUETA ADESIVA VACUO

ETIQUETA ADESIVA INFINITY VÁCUO

Код

90889 00 001

Упак.

10



New

КОНДЕНСАТООТВОДЧИК

CONDENSED DRAIN
 ABLASSVENTIL
 VIDANGE
 VACIADO
 DRENAGEM

ПРИМЕРЫ ПРИМЕНЕНИЯ - APPLICATIONS EXAMPLE - BEISPIELE FÜR ANWENDUNGEN
 EXEMPLES D'APPLICATIONS - EJEMPLO DE APLICACIÓN - EXEMPLOS DE APLICAÇÕES

90259



90030 - 20 1/2
 90975 - 1/2
 90985
 CON310001
 SOL20024C500

90259

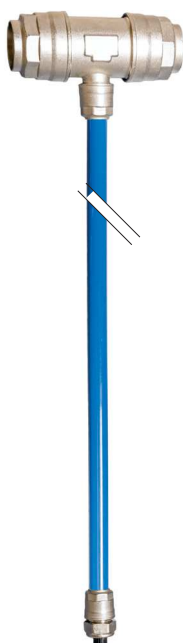

90260 - 20

90250
 90010 - 20 1/2

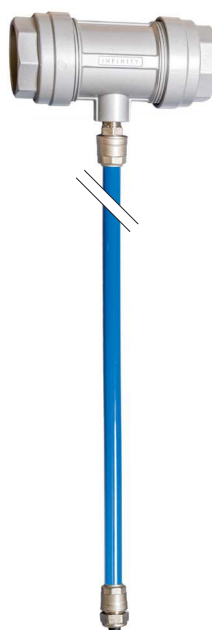

90260 - 20

90259



90010 - 20 1/2
 90986 - 1/2

90250

**АДАПТЕР С ВНУТРЕННЕЙ РЕЗЬБОЙ
 С УСТРОЙСТВОМ СБРОСА КОНДЕНСАТА**

FEMALE FITTING WITH CONDENSE EXHAUST INCORPORATED
 ANSCHLUSS MIT INTEGRIERTEM KONDENSATABLASS INNENGEWINDE
 TÉ FEMELLE FILETÉE, SANS RÉTENTION DES CONDENSATS
 RACOR EN T PARA PURGA DE CONDENSADOS HEMBRA
 CONEXÃO PARA DRENAGEM DE CONDENSADO (ROSCA FÊMEA)

Код	D	F	A	B	C	E	L1	L2	CH	CH1	Упак.
90250 00 017 A	63	1/2	13.5	57.5	88	94	203	53	80	75	1

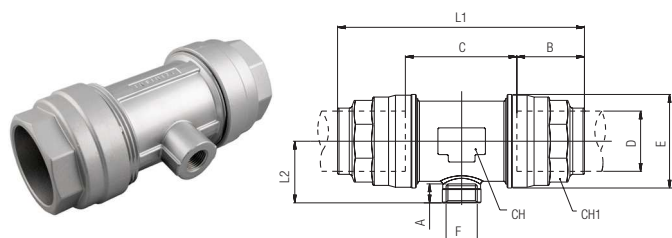

90250 Ø 80-110

АДАПТЕР С ВНУТРЕННЕЙ РЕЗЬБОЙ С УСТРОЙСТВОМ СБРОСА КОНДЕНСАТА

FEMALE FITTING WITH CONDENSE EXHAUST INCORPORATED
 ANSCHLUSS MIT INTEGRIERTEM KONDENSATABLASS INNENGEWINDE
 TÊ FEMELLE FILETÉE, SANS RÉTENTION DES CONDENSATS
 RACOR EN T PARA PURGA DE CONDENSADOS HEMBRA
 CONEXÃO PARA DRENAGEM DE CONDENSADO (ROSCA FÊMEA)

Код	D	F	A	B	C	E	L1	L2	CH	CH1	Упак.
90250 00 002	80	3/4	14.5	91	109	145	291.5	138	6	42	1
90250 00 001	110	3/4	14.5	125.5	150.5	200	401	180	8	42	1

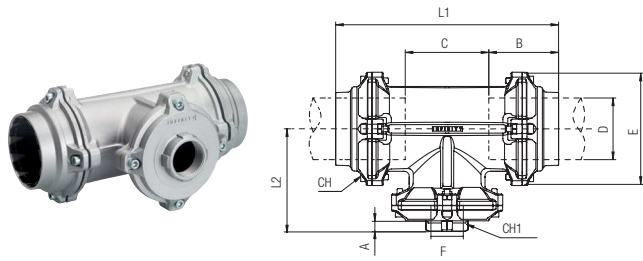

90251

NPTF

АДАПТЕР С ВНУТРЕННЕЙ РЕЗЬБОЙ С УСТРОЙСТВОМ СБРОСА КОНДЕНСАТА

FEMALE FITTING WITH CONDENSE EXHAUST INCORPORATED
 ANSCHLUSS MIT INTEGRIERTEM KONDENSATABLASS INNENGEWINDE
 TÊ FEMELLE FILETÉE, SANS RÉTENTION DES CONDENSATS
 RACOR EN T PARA PURGA DE CONDENSADOS HEMBRA
 CONEXÃO PARA DRENAGEM DE CONDENSADO (ROSCA FÊMEA)

Код	D	F (NPTF)	A	B	C	E	L1	L2	CH	CH1	Упак.
Алюминий - Aluminium - Aluminium - Aluminium - Aluminio - Alumínio											
90251 00 017 A	63	1/2	13.5	57.5	88	94	203	53	80	75	1

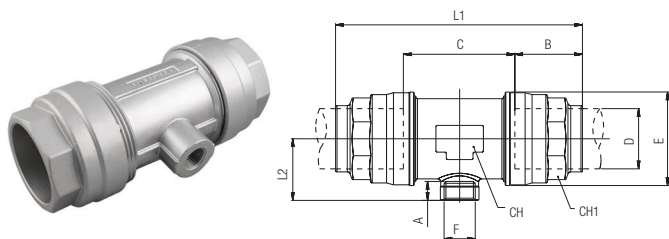

90251 Ø 110

NPTF

АДАПТЕР С ВНУТРЕННЕЙ РЕЗЬБОЙ С УСТРОЙСТВОМ СБРОСА КОНДЕНСАТА

FEMALE FITTING WITH CONDENSE EXHAUST INCORPORATED
 ANSCHLUSS MIT INTEGRIERTEM KONDENSATABLASS INNENGEWINDE
 TÊ FEMELLE FILETÉE, SANS RÉTENTION DES CONDENSATS
 RACOR EN T PARA PURGA DE CONDENSADOS HEMBRA
 CONEXÃO PARA DRENAGEM DE CONDENSADO (ROSCA FÊMEA)

Код	D	F (NPTF)	A	B	C	E	L1	L2	CH	CH1	Упак.
90251 00 001	110	3/4	14	91	109	145	400	180	6	42	1

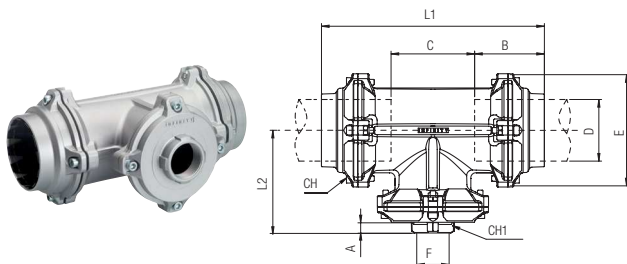

90259

Новинка

ТРОЙНИК ПЕРЕХОДНОЙ С УСТРОЙСТВОМ СБРОСА КОНДЕНСАТА

FITTING WITH CONDENSE EXHAUST INCORPORATED
ANSCHLUSS MIT INTEGRIERTEM KONDENSATABLASS
TÉ, SANS RÉTENTION DES CONDENSATS
RACOR EN T PARA PURGA DE CONDENSADOS
CONEXÃO PARA DRENAGEM DE CONDENSADO

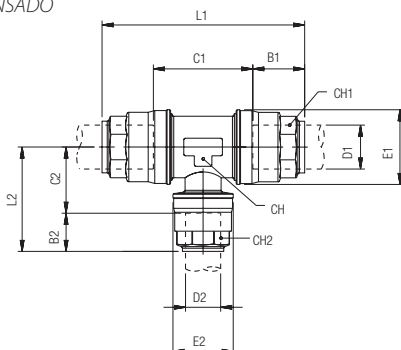

Код	D1	D2	B1	B2	C1	C2	E1	E2	L1	L2	CH	CH1	CH2	Упак.
90259 00 001	20	20	38.5	31.5	45.5	27.5	42.5	34.5	121.5	59	35	35	30	3
90259 00 002	25	20	46	31.5	54.5	31.5	52	34.5	146.5	63	45	45	30	2
90259 00 003	32	20	46	38	54.5	31.5	52	42.5	146.5	70	45	45	35	2
90259 00 004	40	20	52.5	31.5	60	34.5	63	34.5	165.5	66	55	55	30	2
90259 00 005	50	20	52.5	38	60	34.5	63	42.5	165.5	73	55	55	35	2

90260

ФИТИНГ С УСТРОЙСТВОМ СБРОСА КОНДЕНСАТА

FITTING WITH CONDENSE EXHAUST INCORPORATED
ANSCHLUSS FÜR KONDENSATABLASS
PURGE DES CONDENSATS
RACOR CON PURGA DE CONDENSADOS
CONEXÃO PARA DRENAGEM DE CONDENSADO

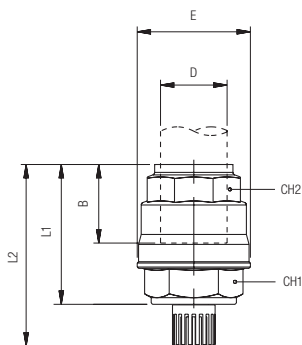

Код	D	B	E	L1	L2	CH1	CH2	Упак.
90260 00 001	20	36	34.5	52.5	67	32	30	2
* 90260 00 002	25	38.5	42.5	57.5	72	32	35	2
* 90260 00 003	32	46	52	67.5	82	38	45	2
* 90260 00 004	40	52	63	77	91.5	50	55	2
* 90260 00 005	50	63.5	73	86.5	101	55	65	1
* 90260 00 006	63	59	92	84	98.5	65	70	1

*** Fino ad esaurimento scorta**
Until the end stock
Nur solange vorrat
Livrabte jusqu'à épuisement du stock
Hasta fin de stock
Ate fim do stock

90986

Новинка

СЛИВ КОНДЕНСАТА

CONDENSE DRAIN
KONDENSATABLASS
PURGE DE CONDENSATION
PURGA DE CONDENSADO
DRENO DE CONDENSADO



90986 00 001
РУЧНОЙ/
ПОЛУАВТО-
МАТИЧЕСКИЙ



90986 00 002
АВТОМАТИЧЕСКИЙ

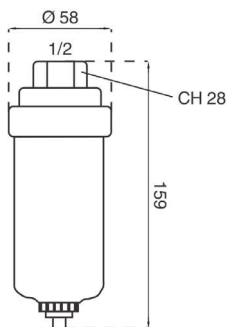

Код	F	Функция Function Funktion Funcion Función Funções	Упак.
90986 00 001	1/2	РУЧНОЙ/ПОЛУАВТОМАТИЧЕСКИЙ	1
90986 00 002	1/2	АВТОМАТИЧЕСКИЙ	1

КЛАПАН СБРОСА КОНДЕНСАТА

CONDENSED DRAIN VALVE
 ABLASSVENTIL
 ROBINET DE VIDANGE
 VÁLVULA DE VACIADO
 VÁLVULA DE DRENAGEM



ТЕХНИЧЕСКИЕ ХАРАКТЕРИСТИКИ

TECHNICAL CHARACTERISTICS
 TECHNISCHE ANGABEN
 CARACTÉRISTIQUES TECHNIQUES
 CARACTERÍSTICAS TÉCNICAS
 CARACTERÍSTICAS TÉCNICAS

2/2 H3



Материалы и компоненты	RU	Component Parts and Materials	GB	Komponenten und Materialien	DE
1 Корпус: латунь		1 Body: Brass		1 Körper: Messing	
2 Резинотехнические уплотнения: NBR		2 Seals: NBR		2 Dichtung: NBR	
3 Направляющая труба: нерж. сталь		3 Welded armature tube: Stainless steel		3 Führungsrohr: Edelstahl	
4 Неподвижный и подвижный сердечник: нерж. сталь		4 Fixed and mobile core: Stainless steel		4 Kern: Edelstahl	
5 Пружины: нержавеющая сталь		5 Springs: Stainless steel		5 Feder: Edelstahl	

Matériaux et Composants	FR	Materiales y componentes	ES	Materiais e Componentes	PT
1 Corps: Laiton		1 Cuerpo: Latón		1 Corpo: Latão	
2 Joints: NBR		2 Juntas: NBR		2 Vedações: NBR	
3 Tube de pilotage: Acier inox		3 Tubo guía: Acero inox.		3 Tubo Guia: Aço-inox	
4 Noyau: Acier inox		4 Núcleo fijo y móvil: Acero inox.		4 Núcleo fixo e móvel: Aço-inox	
5 Ressort: Acier inox		5 Muelle: Acero inox.		5 Mola: Aço-inox	



Максимально допустимое давление

Maximum allowable pressure
 Max. Betriebsdruck
 Pression de service max.
 Presión máxima admisible
 Pressão máxima admissível

16 бар



Температура воздуха, с катушкой класса H

Room temperature with coil class H
 Raumtemperatur, mit Spule der Klasse H
 Température ambiante, avec bobine classe H
 Temperatura ambiente con bobina clase H
 Temperatura ambiente com bobina de classe H

**- 20 °C
 + 80 °C**



Диаметр направляющей трубы

Operator diameter
 Durchmesser Führungsrohr
 Diamètre tube de pilotage
 Diámetro operador
 Diâmetro do operador

13 мм



Степень фильтрации

Degree of filtration
 Abscheidegrad
 Degré de filtration
 Grado de filtración
 Grau de filtração

500 мкм

Уплотнения	Температура	Среда
Seals	Temperature	Medium
Dichtungen	Temperatur	Medium
Joints	Température	Fluides
Juntas	Temperatura	Fluido
Vedações	Temperatura	Fluido

NBR

-10°C

+90°C

Воздух, вода макс. 75 °C
 Air, inert gas, water max. 75 °C
 Luft, Edelgase, Wasser max. 75 °C
 Air, gas neutres, eau max. 75 °C
 Aire, gas inerte, agua máx. 75 °C
 Ar, gás inertes, água máx 75 °C

90975

КЛАПАН СБРОСА КОНДЕНСАТА

CONDENSED DRAIN VALVE
 ABLASSVENTIL
 ROBINET DE VIDANGE
 VÁLVULA DE VACIADO
 VÁLVULA DE DRENAGEM

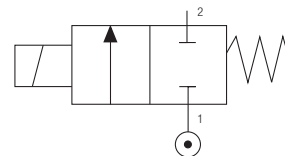
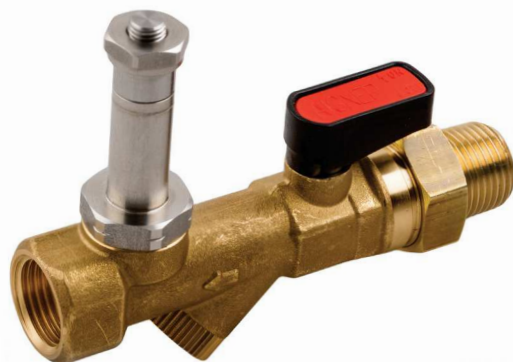

2/2 H3

Ø мм	Вязкость Viscosity Viskosität Viscosité Viscosidad Viscosidade	Kv м ³ /ч	Мощность Power Leistung Puissance Potencia Potência		ΔP бар	
			Макс., сСт	EXH	DC Вт	AC ВА
3	53	0.21	8	-	0	11.4
			14	-	0	15.1
			22	-	0	20
			-	14	0	10.6
			-	21	0	17.1
			-	31	0	24.1

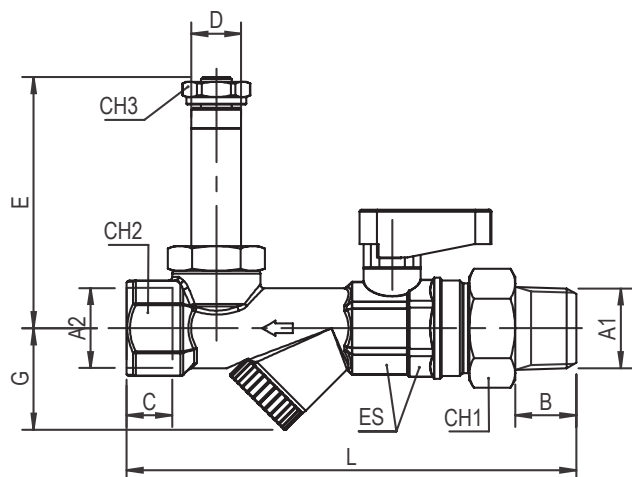

Код	A1	A2	B	C	D	CH1	CH2	CH3	L	E	ES	G
90975 00 004	3/8	1/2	11,5	12	13	27	25	16	113,5	65,5	22 - 23	26,5
90975 00 005	1/2	1/2	16	12	13	27	25	16	117,5	65,5	22 - 23	26,5

90985 00 001

ТАЙМЕР АНАЛОГОВЫЙ DIN43650A

ANALOGUE TIMER DIN43650A

TIMER ANALOG DIN43650A

TIMER ANALOG DIN43650A

ANALÓGICO TEMPORIZADOR DIN43650A

TIMER ANALOG DIN43650A



Характеристики

Features

Features

Traits

Características

Recursos

- 24 - 240 В АС/DC 50/60 Гц
- IP65 - EN6052
- 1 А Макс.
- 0,5 - 10 с ВКЛ.
- 0,5 - 45 Мин. ВЫКЛ
- Сброс/Тест



Температура

Temperature

Temperatur

Température

Temperatura

Temperatura

- 10 °C
- + 50 °C

РАЗЪЕМ

CONNECTOR
STECKER
CONNECTEURS
CONECTOR
CONECTOR

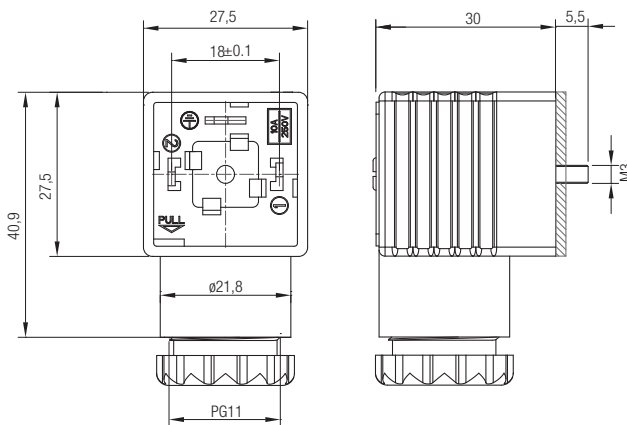

Электрическая схема

Wiring

Elektroschema

Schéma électrique

Esquema eléctrico

Esquema elétrico

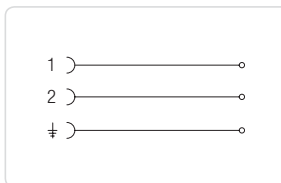

CON31 000 01

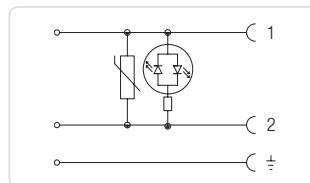

CON32 024 00
CON32 110 00
CON32 250 00

Код Code Nummer Code Código Código	Цвет Colour Farbe Couleur Color Cor	Характеристика Characteristics Eigenschaften Caractéristiques Características Características	Размер Size Grösse Dimensions Talla Tamanho
CON31 000 01	■	2-ПОЛ. - PINS - PINS - BROCHES - PINS - PINOS	30-36
CON32 024 00	□	LED + VDR 0 - 24 B	30-36
CON32 110 00	□	LED + VDR 110 B	30-36
CON32 250 00	□	LED + VDR 220 B	30-36

■ **ЧЕРНЫЙ**
BLACK
SCHWARZ
NOIR
NEGRO
PRETO

□ **ПРОЗРАЧНЫЙ**
TRANSPARENT
TRANSPARENT
TRANSPARENT
TRANSPARENT
TRANSPARENT

СТЕПЕНЬ ЗАЩИТЫ

DEGREE OF PROTECTION
SCHUTZART
DEGRÉ DE PROTECTION
GRADO DE PROTECCIÓN
GRAU DE PROTEÇÃO

IP65 IEC
60529

ДИАМЕТР КАБЕЛЯ

CABLE DIAMETER
KABELDURCHMESSE
R DIAMÈTRE DU
CABLE DIÁMETRO
DO CABO

6÷8 мм и
8÷11 для разм.
30-36 мм

VDR: С варисторами для защиты от перенапряжения

Fitted with varistors as surge protection device.
Ausgestattet mit Varistor als ÜberSpannungsschutz.
Équipé avec varistance de protection contre les sur Tensions.
Dotado de Varistor como dispositivo de protección de sobretensiones.
Dotados de Varistor como dispositivo de proteção de sobretenção.

КАТУШКИ

SOLENOIDS
SPULEN
BOBINES
BOBINAS
SOLENÓIDES

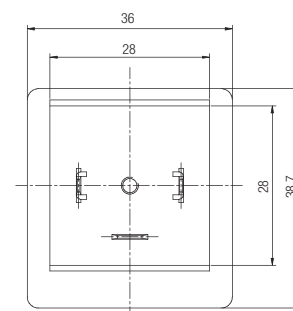
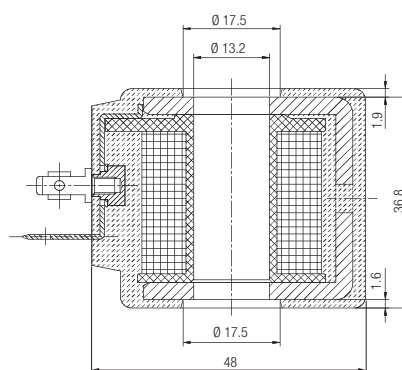
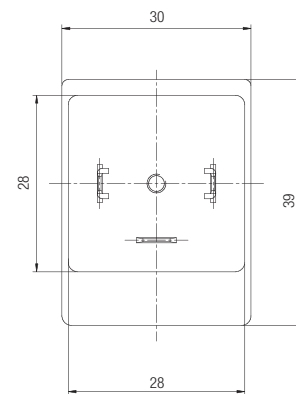
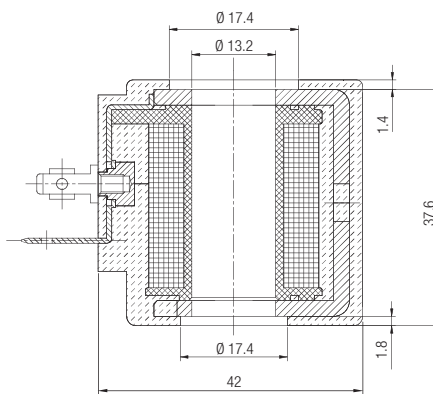

Код Code Nummer Code Código Código	Диаметр трубки Operator diameter Durchmesser Führungsrohr Diamètre tube de pilotage Diámetro operador Diâmetro do operador	Размер Size Größe Dimensions Talla Tamanho	Напряжение Voltage Leistung Tension Tensión Tensão	Мощность Function Leistung Puissance Potencia Potência	Напряжение Voltage Leistung Tension Tensión Tensão
SOL20 024 C 5 000	13	30	24 B DC	8 w	48 B AC
SOL20 024 C 6 000	13	30	24 B DC	14 w	48 B AC
SOL21 024 C 7 000	13	36	24 B DC	22 w	
SOL20 024 A A 000	13	30	24 B AC	14 VA	
SOL20 110 A A 000	13	30	110 B AC	14 VA	
SOL20 220 A A 000	13	30	220 B AC	14 VA	
SOL20 024 A B 000	13	30	24 B AC	21 VA	
SOL20 110 A B 000	13	30	110 B AC	21 VA	
SOL20 220 A B 000	13	30	220 B AC	21 VA	110 B DC
SOL21 024 A C 000	13	36	24 B AC	31 VA	
SOL21 110 A C 000	13	36	110 B AC	31 VA	
SOL21 220 A C 000	13	36	220 B AC	31 VA	110 B DC

КОЛЕБАНИЯ НАПРЯЖЕНИЯ

VOLTAGE TOLERANCE
SPANNUNGSTOLERANZ
TOLÉRENCE DE LA TENSION
TOLERANCIA DE TENSIÓN
TOLERÂNCIA DE TENSÃO

±10 %

КЛАСС ИЗОЛЯЦИИ

CLASS OF ISOLATION
ISOLIERSTOFFKLASSE
CLASSE D'ISOLATION
CLASE DE AISLAMIENTO
CLASSE DE ISOLAMENTO

H CEI EN
60085

ЭКСПЛУАТАЦИОННЫЙ ЦИКЛ

DUTY RATE
ARBEITSZYKLUS
CYCLE DE SERVICE
CICLO DE TRABAJO
CICLO TRABALHO

100 %
ED

ПОЛЮСА РАЗЪЕМА

TERMINALS
ANSCHLÜSSE
CONNEXION
TERMINALES
TERMINAIS

DIN 43650

СТЕПЕНЬ ЗАЩИТЫ

DEGREE OF PROTECTION
SCHUTZART
DEGRÉ DE PROTECTION
GRADO DE PROTECCIÓN
GRAU DE PROTEÇÃO

IP65 IEC
60529

СРАЗЪЕМОМ
WITH CONNECTOR
MIT STECKER
AVEC CON-
NECTEUR
CON CONECTOR
COM CONECTOR

ПРИНАДЛЕЖНОСТИ

ACCESSORIES
ZUBEHÖR
ACCESSOIRES
ACCESORIOS
ACESSÓRIOS

661

МУФТА БРС С НАРУЖНОЙ РЕЗЬБОЙ
MALE SOCKET
VERSCHLUSS-KUPPLUNG MIT AUSSENGEWINDE
COUPLEUR MÂLE
ENCHUFE MACHO
SOQUETE COM ROSCA MACHO



Код	
00661 00 001	1/4
00661 00 002	3/8
00661 00 003	1/2

665

МУФТА БРС С ШТУЦЕРОМ ПОД РЕЗИНОВЫЙ ШЛАНГ
SOCKET WITH REST FOR RUBBER HOSE
VERSCHLUSS-KUPPLUNG MIT SCHLAUCHTÜLLE
COUPLEUR À DOUILLE ANNELÉE POUR TUBE
ENCHUFE ESPIGA
SOQUETE COM ESPIGÃO
PARA MANGUEIRA DE BORRACHA



Код	
00665 00 001	6
00665 00 002	8
00665 00 003	10
00665 00 004	12

662

МУФТА БРС С ВНУТРЕННЕЙ РЕЗЬБОЙ
FEMALE SOCKET
VERSCHLUSS-KUPPLUNG MIT
INNENGEWINDE COUPLEUR FEMELLE
ENCHUFE HEMBRA
SOQUETE COM ROSCA FÊMEA



Код	
00662 00 001	1/4
00662 00 002	3/8
00662 00 003	1/2

261AC

НИППЕЛЬ БРС СТАЛЬНОЙ С НАРУЖНОЙ РЕЗЬБОЙ
STEEL MALE PLUG
STECKER MIT AUSSENGEWINDE AUS STAHL
EMBOUT MÂLE EN ACIER
ADAPTADOR EN ACERO MACHO
PLUG EM AÇO COM ROSCA MACHO



Код	
261AC 00 51 03 ZI	1/4
261AC 00 51 04 ZI	3/8
261AC 00 51 05 ZI	1/2

664

МУФТА БРС С КОМПРЕССИОННЫМ ФИТИНГОМ
COMPRESSION SOCKET
VERSCHLUSS-KUPPLUNG MIT
ÜBERWURFVERSCHRAUBUNG
COUPLEUR RACCORD À COIFFE
ENCHUFE TUBO
SOQUETE COM CONEXÃO PUSH-ON



Код	
00664 00 001	6/4
00664 00 002	8/6
00664 00 005	10/6.5
00664 00 003	10/8
00664 00 006	12/8
00664 00 004	12/10

262AC

НИППЕЛЬ БРС СТАЛЬНОЙ, С ВНУТРЕННЕЙ РЕЗЬБОЙ
STEEL FEMALE PLUG
STECKER MIT INNENGEWINDE AUS STAHL
EMBOUT FEMELLE EN ACIER
ADAPTADOR EN ACERO HEMBRA
PLUG EM AÇO COM ROSCA FÊMEA

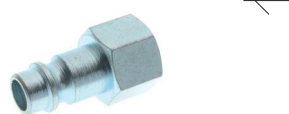

Код	
262AC 00 51 03 ZI	1/4
262AC 00 51 04 ZI	3/8
262AC 00 51 05 ZI	1/2

265AC

НИППЕЛЬ БРС СТАЛЬНОЙ С ШТУЦЕРОМ ПОД ШЛАНГ

STEEL PLUG WITH REST FOR RUBBER HOSE
 STECKER MIT SCHLAUCHTÜLLE AUS STAHL
 EMBOUT À DOUILLE ANNELÉE POUR TUBE EN ACIER
 ADAPTADOR EN ACERO ESIPIGA
 PLUG EM AÇO COM ESIPIGAO PARA TUBO DE BORRACHA

Код	
265AC 00 51 X4 ZI	6
265AC 00 51 X7 ZI	8
265AC 00 51 X9 ZI	10
265AC 00 51 Y1 ZI	12



628

ЗАЩИТА МУФТЫ БРС ИЗ EPDM

EPDM SOCKET PROTECTION
 KUPPLUNGSSCHUTZ IN EPDM
 PROTECTION POUR COUPLEUR EN EPDM
 PROTECCIÓN ENCHUFE EN EPDM
 CAPA DE PROTEÇÃO PARA SOQUETE EM EPDM

Код	
00628 00 20 00 00	*6 - 8 - 10 - 12



* Обрежьте конический кончик под диаметр кабеля.

Cut the protection on external tube diameter sign.
 Schneiden Sie das Schutzrohr gemäss den Markierungen auf den gewünschten Durchmesser.
 Couper le tube de protection sur la marque en fonction du diamètre désiré.
 Cortar la protección en función de la escritura que indica el diámetro externo del tubo utilizado.
 Corte a proteção na marcação correspondente ao diâmetro externo do tubo a ser utilizado.

191

МУФТА БРС С НАРУЖНОЙ РЕЗЬБОЙ

MALE SOCKET
 VERSCHLUSS-KUPPLUNG MIT AUSSENGEWINDE
 COUPLEUR MÂLE
 ENCHUFE MACHO
 SOQUETE COM ROSCA MACHO

Код	
00191 00 001	1/4
00191 00 002	3/8
00191 00 003	1/2



261

НИППЕЛЬ БРС С НАРУЖНОЙ РЕЗЬБОЙ

MALE PLUG
 STECKER MIT AUSSENGEWINDE
 EMBOUT MÂLE
 ADAPTADOR MACHO
 PLUG COM ROSCA MACHO

Код	
00261 00 01 03 NB	1/4
00261 00 01 04 NB	3/8
00261 00 01 05 NB	1/2



192

МУФТА БРС С ВНУТРЕННЕЙ РЕЗЬБОЙ

FEMALE SOCKET
 VERSCHLUSS-KUPPLUNG MIT INNENGEWINDE
 COUPLEUR FEMELLE
 ENCHUFE HEMBRA
 SOQUETE COM ROSCA FÊMEA

Код	
00192 00 001	1/4
00192 00 002	3/8
00192 00 003	1/2



262

НИППЕЛЬ БРС С ВНУТРЕННЕЙ РЕЗЬБОЙ

FEMALE PLUG
 STECKER MIT INNENGEWINDE
 EMBOUT FEMELLE
 ADAPTADOR HEMBRA
 PLUG COM ROSCA FÊMEA

Код	
00262 00 01 03 NB	1/4
00262 00 01 04 NB	3/8
00262 00 01 05 NB	1/2



193

МУФТА БРС С КОМПРЕССИОННЫМ ФИТИНГОМ И ПРУЖИНОЙ

COMPRESSION SOCKET WITH SPRING
 VERSCHLUSS-KUPPLUNG MIT KNICKSCHUTZFEDER
 COUPLEUR AVEC RESSORT DE PROTECTION
 ENCHUFE TUBO CON MUELLE
 SOQUETE COM CONEXÃO PUSH-ON COM MOLA

Код	
00193 00 001	6/4
00193 00 002	8/6
00193 00 004	10/6.5
00193 00 003	10/8
00193 00 005	12/10



263

МУФТА БРС С КОМПРЕССИОННЫМ ФИТИНГОМ И ПРУЖИНОЙ

COMPRESSION PLUG WITH SPRING
 STECKER MIT KNICKSCHUTZFEDER
 EMBOUT AVEC RESSORT DE PROTECTION
 ADAPTADOR TUBO CON MUELLE
 PLUG COM CONEXÃO PUSH-ON COM MOLA

Код	
00263 00 001	6/4
00263 00 002	8/6
00263 00 003	10/8
00263 00 004	12/10



50020

АДАПТЕР ЦАНГОВЫЙ С НАРУЖНОЙ ПАРАЛЛЕЛЬНОЙ РЕЗЬБОЙ

STRAIGHT MALE ADAPTOR (PARALLEL)
GERADE EINSCHRAUBVERSCHRAUBUNG ZYLINDRISCH

RACCORD DROIT MÂLE, CYLINDRIQUE
RACOR RECTO MACHO CILÍNDRICO CON TÓRICA
CONEXÃO RETA COM ROSCA PARALELA



Код			
50020 00 021	3	M5	
50020 00 034	4	M3	
50020 00 001	4	M5	
50020 00 002	4	1/8	
50020 00 022	4	1/4	
50020 00 018	5	M5	
50020 00 019	5	1/8	
50020 00 036	5	1/4	
50020 00 020	6	M5	
50020 00 003	6	1/8	
50020 00 004	6	1/4	
50020 00 027	6	3/8	
50020 00 028	6	1/2	
50020 00 005	8	1/8	
50020 00 006	8	1/4	
50020 00 007	8	3/8	
50020 00 029	8	1/2	
50020 00 008	10	1/4	
50020 00 009	10	3/8	
50020 00 031	10	1/2	
50020 00 032	12	1/4	
50020 00 011	12	3/8	
50020 00 023	12	1/2	
50020 00 024	14	3/8	
50020 00 025	14	1/2	
50020 00 012	6	M12x1	
50020 00 013	6	M12x1.25	
50020 00 014	6	M12x1.5	
50020 00 017	8	M12x1.5	

1027

АДАПТЕР ПРЯМОЙ ПОВОРОТНЫЙ С НР + КОМПРЕССИОННЫЙ ФИТИНГ С ПРУЖИНОЙ

ORIENTING STRAIGHT MALE ADAPTOR (PARALLEL) + NUT WITH SPRING
GERADE VERSCHRAUBUNG

ZYLINDRISCH (DREHBAR) + KNICKSCHUTZFEDER
RACCORD ORIENTABLE DROIT MÂLE, CYLINDRIQUE
AVEC RESSORT DE PROTECTION

RACOR RECTO ORIENTABLE MACHO CILÍNDRICO CON TÓRICA + TUERCA CON MUELLE
CONEXÃO RETA ORIENTÁVEL MACHO COM ROSCA PARALELA + PORCA COM MOLA



* Размеры для трубок из ПОЛИУРЕТАНА.
Particular sizes for the POLYURETHANE tubing.
Spezial Abmessungen für POLYURETHAN Rohre.
Dimensions spécifiques pour tube POLYURETHANE.
Medidas específicas para tubo en POLIURETANO.
Tamanhos específicos para tubos de POLIURETANO.

Код			
01027 00 001	6/4	1/8	
01027 00 002	6/4	1/4	
01027 00 003	8/6	1/8	
01027 00 004	8/6	1/4	
* 01027 00 005	10/6.5	1/4	
01027 00 006	10/8	1/4	
* 01027 00 007	12/8	3/8	
01027 00 008	12/10	3/8	

6300

КРАН ШАРОВОЙ МУФТОВЫЙ ВР RP ISO 7 / ВР RP ISO 7

FEMALE RP ISO 7 - FEMALE RP ISO 7 VALVE
KUGELHAHN INNENGEW. RP ISO 7 - INNENGEW. RP ISO 7
ROBINET - TARAUDAGE RP ISO 7

VÁLVULA HEMBRA RP ISO 7 - HEMBRA RP ISO 7
VÁLVULA ROSCA FÊMEA RP ISO 7 - ROSCA FÊMEA RP ISO 7



Код			
06300 00 001	1/8	1/8	
06300 00 002	1/4	1/4	
06300 00 003	3/8	3/8	
06300 00 004	1/2	1/2	
06300 00 055	3/4	3/4	

6310

ШАРОВОЙ КРАН С КОНИЧЕСКОЙ НР R ISO 7 - ПАРАЛЛЕЛЬНОЙ ВР RP ISO 7

TAPER MALE R ISO 7 - FEMALE RP ISO 7 VALVE
KUGELHAHN AUSSENGEW. KONISCH R ISO 7 - INNENGEW. RP ISO 7

ROBINET FILETAGE R ISO 7 - TARAUDAGE RP ISO 7
VÁLVULA MACHO CÔNICO R ISO 7 - HEMBRA RP ISO 7
VÁLVULA ROSCA MACHO CÔNICA R ISO 7 - ROSCA FÊMEA RP ISO 7



Код			
06310 00 001	1/8	1/8	
06310 00 002	1/4	1/8	
06310 00 003	1/4	1/4	
06310 00 004	3/8	3/8	
06310 00 005	1/2	1/2	
06310 00 066	3/4	3/4	

6067

ШАРОВОЙ КРАН С НР G ISO 228 - ВР G ISO 228

BALL VALVE, FEMALE G ISO 228 - FEMALE G ISO 228
KUGELHAHN, INNENGEW. G ISO 228 - INNENGEW. G ISO 228

ROBINET TARAUDAGE G ISO 228
VÁLVULA A ESFERA HEMBRA G ISO 228 - HEMBRA G ISO 228
VÁLVULA DE ESFERA, FÊMEA G ISO 228 - FÊMEA G ISO 228



Код	
06067 00 001	1/2
06067 00 002	3/4
06067 00 003	1"
06067 00 004	1"1/4
06067 00 005	1"1/2
06067 00 006	2"

6060

КЛАПАН ШИБЕРНЫЙ

SLIDE VALVE
HANDSCHIEBEVENTILE VANNE
COULISSANTE VÁLVULA DE CORREDERA VÁLVULA DESLIZANTE



Код	
06060 00 001	1/8
06060 00 002	1/4
06060 00 003	3/8
06060 00 004	1/2

SS12

ТРУБКА ПОЛИАМИДНАЯ СПИРАЛЬНАЯ БЕЗ ПРЯМЫХ КОНЦОВ

POLYAMIDE SPIRAL WITHOUT TANGS
SPIRALROHRE AUS POLYAMID OHNE GERADE ENDEN
TUBE SPIRALÉ EN POLYAMIDE SANS EXTRÉMITÉS
DROITES ESPIRAL EN POLIAMIDA SIN TERMINALES
ESPIRAL DE POLIAMIDA SEM ABAS



Код	■	OD (мм)	ID (мм)	Длина линейн.(м)	Упак.
SS12 0064 030	BL	6	4	30	1
SS12 0086 030	BL	8	6	30	1
SS12 0108 030	BL	10	8	30	1
SS12 0121 030	BL	12	10	30	1

SDPU

ТРУБКА ПОЛИАМИДНАЯ СПИРАЛЬНАЯ С ПРЯМЫМИ КОНЦАМИ, ТВЕРДОСТЬ ПО ШОРУ 95

SPIRAL POLYURETHANE POLYETHER 95 SHORE A WITH TANGS
SPIRALROHRE AUS POLYURETHAN-POLYETHER 95 SHORE A MIT GERADEN ENDEN
TUBE SPIRALÉ EN POLYURÉTHANE POLYÉTHÉR 95 SHORE A AVEC EXTRÉMITÉS
DROITES ESPIRAL EN POLIURETANO POLIÉTER 95 SHORE A CON TERMINALES
ESPIRAL DE POLIURETANO POLIÉTER 95 SHORE A COM ABAS



Код	■	OD (мм)	ID (мм)	Длина линейн.(м)	Упак.
SDPU 0064 004	AZ	6	4	4	1
SDPU 0085 505	AZ	8	5.5	5	1
SDPU 0106 505	AZ	10	6.5	5	1
SDPU 0120 805	AZ	12	8	5	1
SDPU 0085 075	AZ	8	5.5	7.5	1
SDPU 0106 575	AZ	10	6.5	7.5	1
SDPU 0120 875	AZ	12	8	7.5	1

ТВРПМ

ТРУБКА ПВХ МНОГОСЛОЙНАЯ - ДЛИНА 25 М

PVC MULTYLAYER SUPERFLEXIBLE HOSE - LENGHT 25 Mt
MEHRSCHICHTIGES PVC-ROHR SUPERFLEXIBEL - LÄNGE 25 Mt
TUBE MULTICOUCHE SUPERFLEXIBLE PVC - ROULEAU DE 25 Mt
TUPO MULTICAPA SUPERFLEXIBLE PVC - LONGITUD 25 Mt
TUBO MULTICAMADA SUPERFLEXIVEIS PVC - LUNGHEZZA 25 Mt

Новинка



Код	■	OD (мм)	ID (мм)	Упак.
ТВРПМ 011 06	AZ	11	6,3	1
ТВРПМ 013 08	AZ	13	8	1
ТВРПМ 145 09	AZ	14,5	9	1
ТВРПМ 155 10	AZ	15,5	10	1
ТВРПМ 191 27	AZ	19	12,7	1
ТВРПМ 023 16	AZ	23	16	1

1770

ХОМУТ ЧЕРВЯЧНЫЙ ДЛЯ ТРУБКИ ПВХ

CLAMPS FOR PVC HOSES
KLEMMEN FÜR PVC-ROHRE
COLLIERS DE SERRAGE POUR TUBES PVC
ABRAZADERAS PARA TUBO PVC
ABRAÇADEIRA POR TUBO PVC

Новинка

Код	D	в	s	Упак.
01770 00 001	8 - 12	9 мм	0,6 мм	50
01770 00 002	10 - 16	9 мм	0,6 мм	50
01770 00 003	12 - 20	9 мм	0,6 мм	50
01770 00 004	16 - 27	9 мм	0,6 мм	50

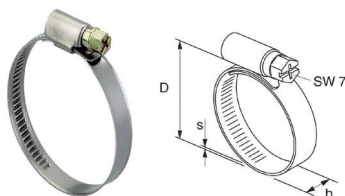

3040

АДАПТЕР С НАРУЖНОЙ РЕЗЬБОЙ ПОД ШЛАНГ

MALE HOSE ADAPTER (TAPER)
 SCHLAUCHTÜLLE AUSSENGEW. KONISCH
 DOUILLE ANNELÉE, CONIQUE
 ESPIGA MACHO CÔNICA
 EPIGÃO COM ROSCA MACHO CÔNICA

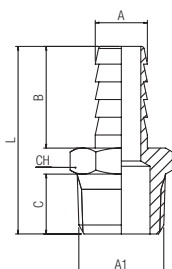

Новинка

Код	A	A1	B	C	L	CH	Упак.
03040 00 01 BS NB	6	1/8	19.5	7.5	32	12	10
03040 00 01 BT NB	6	1/4	19.5	11	35.5	14	10
03040 00 01 BZ NB	7	1/8	19.5	7.5	32	12	10
03040 00 01 BX NB	7	1/4	19.5	11	35.5	14	10
03040 00 01 BY NB	8	1/8	19.5	7.5	32	12	10
03040 00 01 BJ NB	8	1/4	19.5	11	35.5	14	10
03040 00 01 BK NB	8	3/8	19.5	11.5	36	17	10
03040 00 01 CA NB	9	1/8	19.5	7.5	32	12	10
03040 00 01 CB NB	9	1/4	19.5	11	35.5	14	10
03040 00 01 CC NB	9	3/8	19.5	11.5	36	17	10
03040 00 01 CD NB	9	1/2	19.5	14	39	22	10
03040 00 01 CE NB	10	1/8	19.5	7.5	32	12	10
03040 00 01 CF NB	10	1/4	19.5	11	35.5	14	10
03040 00 01 CG NB	10	3/8	19.5	11.5	36	17	10
03040 00 01 CH NB	10	1/2	19.5	14	39	22	10
03040 00 01 VB NB	11	1/8	19.5	7.5	32	12	10
03040 00 01 RP NB	11	1/4	19.5	11	35.5	14	10
03040 00 01 QR NB	11	3/8	19.5	11.5	36	17	10
03040 00 01 VF NB	11	1/2	19.5	14	39	17	10
03040 00 01 CI NB	12	1/4	19.5	11	35.5	14	10
03040 00 01 CL NB	12	3/8	19.5	11.5	36	17	10
03040 00 01 CM NB	12	1/2	19.5	14	39	22	10
03040 00 01 CN NB	14	3/8	19.5	11.5	36	17	10
03040 00 01 DB NB	14	1/2	19.5	14	39	22	10
03040 00 01 5P NB	15	1/4	19.5	11	35.5	22	10
03040 00 01 1G NB	15	3/8	19.5	11.5	36	17	10
03040 00 01 CP NB	15	1/2	19.5	14	39	22	10
03040 00 01 VG NB	15	3/4	19.5	14.5	43.5	27	10
03040 00 01 CQ NB	16	3/8	19.5	11.5	36	17	10
03040 00 01 CR NB	16	1/2	19.5	14	39	22	10
03040 00 01 CS NB	16	3/4	19.5	16.5	43.5	27	10
03040 00 01 CT NB	17	3/8	19.5	11.5	36	18	10
03040 00 01 CU NB	17	1/2	19.5	14	39	22	10

3044

АДАПТЕР С НАРУЖНОЙ РЕЗЬБОЙ ПОД ШЛАНГ, С УПЛОТНИТЕЛЬНЫМ КОЛЬЦОМ

MALE HOSE ADAPTER (PARALLEL) WITH O-RING
 SCHLAUCHTÜLLE AUSSENGEW. ZYLINDRISCH MIT O-RING
 DOUILLE ANNELÉE, CYLINDRIQUE AVEC JOINT TORIQUE
 EPIGA MACHO CILÍNDRICA CON TÓRICA
 EPIGÃO COM ROSCA MACHO PARALELA E O-RING

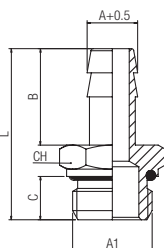

Новинка

Код	A	A1	B	C	L	CH	Упак.
03044 00 023	6	1/4	20	8	34.5	16	10
03044 00 002	7	1/8	20	6	31	13	10
03044 00 003	7	1/4	20	8	34.5	16	10
03044 00 004	8	1/8	20	6	31	13	10
03044 00 005	8	1/4	20	8	34.5	16	10
03044 00 024	8	3/8	20	9	35.5	19	10
03044 00 015	8	1/2	20	10	37.5	24	10
03044 00 006	9	1/8	20	6	31	13	10
03044 00 007	9	1/4	20	8	34.5	16	10
03044 00 008	9	3/8	20	9	35.5	19	10
03044 00 025	10	1/4	20	8	34.5	16	10
03044 00 026	10	3/8	24	9	39.5	19	10
03044 00 027	10	1/2	22	10	39.5	24	10
03044 00 009	12	1/4	20	8	34.5	16	10
03044 00 010	12	3/8	20	9	35.5	19	10
03044 00 011	12	1/2	22	10	39.5	24	10
03044 00 016	13	1/2	22	10	39.5	24	10
03044 00 028	14	1/4	24	8	38.5	16	10
03044 00 020	14	3/8	24	9	39.5	19	10
03044 00 021	14	1/2	24	10	41.5	24	10
03044 00 012	17	3/8	24	9	39.5	19	10
03044 00 013	17	1/2	24	10	41.5	24	10

мин. макс.



Температура

- 20 °C

+ 80 °C

301

Новинка

ПИСТОЛЕТ ВОЗДУШНЫЙ С ТРУБКОЙ ИЗ НЕРЖАВЕЮЩЕЙ СТАЛИ

BLOWGUN WITH STAINLESS STEEL PIPE
 BLASPISTOLE MIT EDELSTAHL ROHR
 SOUFFLETTE AVEC EMBOUT ACIER INOXYDABLE
 PISTOLA DE SOPLADO CON TUBO ACERO INOXIDABLE
 PISTOLA DE AR COM BICO DE AÇO INOXIDÁVEI

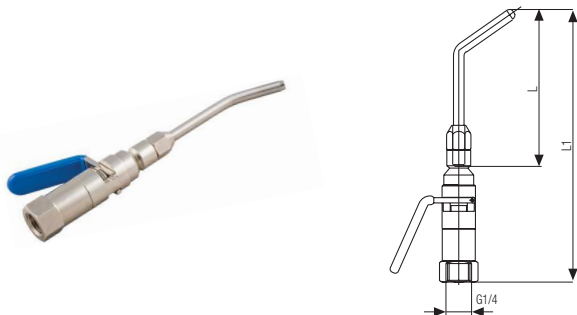

Код	L	L1	Упак.
00301 00 001	90	163	10
00301 00 002	200	273	1
00301 00 003	290	363	1

	мин.	макс.
Температура	- 10 °C	+ 80 °C
Давление	10 бар (1.0 МПа)	
450 Нл/мин @ 6 бар - 616 Нл/мин @ 8 бар		
83 дБ @ 6 бар		
85 дБ @ 6,3 бар		
Усилие на рукоятке - Force on handle Kraft am Griff - Force sur la poignée Fuerza en el mango - Força no punho	23,5 Н @ 6 бар	
Сила струи - Blowing force Kraft der Schlag - Force de soufflage Fuerza que sopla - Força de sopra	4,6 Н @ 6 бар	
2003/10/CE	Макс. 85 дБ	
OSHA 1910.95 (b)	Макс. 90 дБ 8 ч	

361

Новинка

ПИСТОЛЕТ ВОЗДУШНЫЙ С ТРУБКОЙ ИЗ НЕРЖАВЕЮЩЕЙ СТАЛИ

BLOWGUN WITH STAINLESS STEEL PIPE
 BLASPISTOLE MIT EDELSTAHL ROHR
 SOUFFLETTE AVEC EMBOUT ACIER INOXYDABLE
 PISTOLA DE SOPLADO CON TUBO ACERO INOXIDABLE
 PISTOLA DE AR COM BICO DE AÇO INOXIDÁVEI

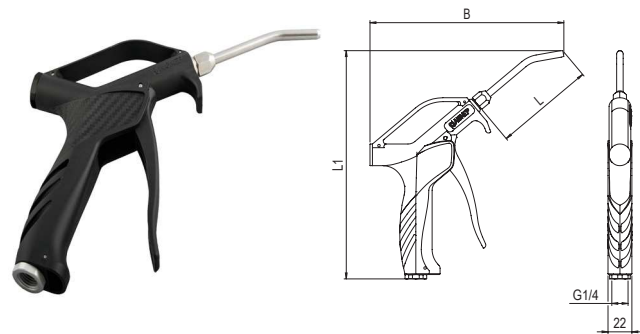

Код	L	L1	B	Упак.
00361 00 001	90	210,5	179	10

	мин.	макс.
Температура	- 10 °C	+ 80 °C
Давление	12 бар (1.2 МПа)	
433 Нл/мин @ 6 бар - 533 Нл/мин @ 8 бар		
81 дБ @ 6 бар		
85 дБ @ 8 бар		
Усилие на рукоятке - Force on handle Kraft am Griff - Force sur la poignée Fuerza en el mango - Força no punho	19,8 Н @ 6 бар	
Сила струи - Blowing force Kraft der Schlag - Force de soufflage Fuerza que sopla - Força de sopra	3,7 Н @ 6 бар	
2003/10/CE	Макс. 85 дБ	
OSHA 1910.95 (b)	Макс. 90 дБ 8 ч	

362

Новинка

ПИСТОЛЕТ ВОЗДУШНЫЙ С ТРУБКОЙ ИЗ НЕРЖАВЕЮЩЕЙ СТАЛИ В БЕЗОПАСНОМ ИСПОЛНЕНИИ

BLOWGUN WITH STAINLESS STEEL SAFETY PIPE
 BLASPISTOLE MIT EDELSTAHL-SICHERHEITS ROHR
 SOUFFLETTE AVEC EMBOUT DE SÉCURITÉ ACIER INOXYDABLE
 PISTOLA DE SOPLADO CON TUBO DE SEGURIDAD ACERO
 INOXIDABLE PISTOLA DE AR COM BICO DE SEGURANÇA DE AÇO INOXIDÁVEL

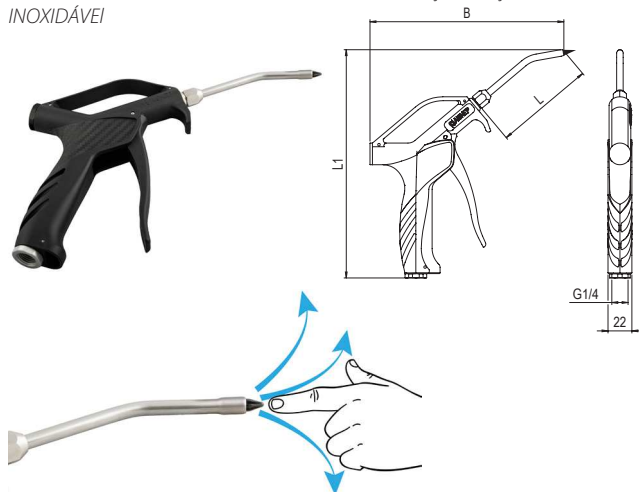

Код	L	L1	В	Упак.
00362 00 001	90	210,5	185,5	10
		мин.	макс.	
Температура		- 10 °C	+ 80 °C	
Давление		12 бар (1.2 МПа)		
383 Нл/мин @ 6 бар - 500 Нл/мин @ 8 бар				
81 дБ @ 6 бар				
85 дБ @ 8 бар				
Усилие на рукоятке - Force on handle Kraft am Griff - Force sur la poignée Fuerza en el mango - Força no punho			19,8 Н @ 6 бар	
Сила струи - Blowing force Kraft der Schlag - Force de soufflage Fuerza que sopla - Força de sopra			3,4 Н @ 6 бар	
2003/10/CE			Макс. 85 дБ	
OSHA 1910.95 (b)			Макс. 90 дБ 8 ч	
OSHA 1910.242 (b)			Макс. 30 PSI (2,1 бар) при блокировании	

363

Новинка

ПИСТОЛЕТ ВОЗДУШНЫЙ С ТРУБКОЙ ИЗ НЕРЖАВЕЮЩЕЙ СТАЛИ В БЕЗОПАСНОМ ИСПОЛНЕНИИ С ДВУМЯ ВХОДНЫМИ ПОРТАМИ

BLOWGUN WITH STAINLESS SAFETY PIPE DOUBLE FEED
 BLASPISTOLE MIT EDELSTAHL-SICHERHEITS ROHR DOPPELEINZUG
 SOUFFLETTE AVEC EMBOUT DE SÉCURITÉ INOX AVEC DOUBLE ALIMENTATION
 PISTOLA DE SOPLADO CON TUBO DE SEGURIDAD INOX DOBLE ALIMENTACION
 PISTOLA DE AR COM BICO DE SEGURANÇA EM INOX ALIMENTAÇÃO DUPLA

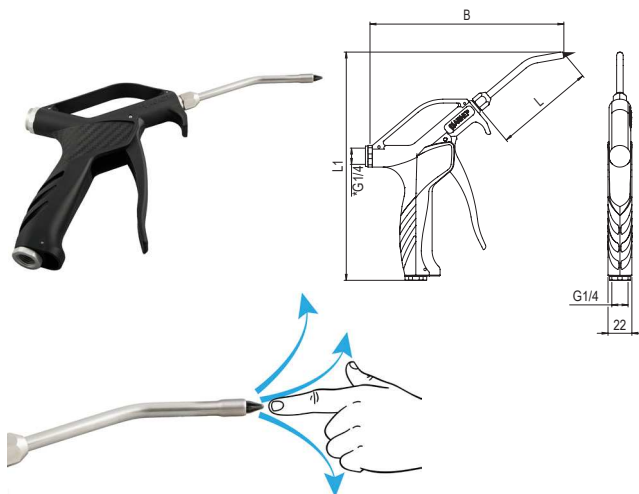

Код	L	L1	В	Упак.
00363 00 001	90	210,5	190,5	10
В комплекте одна пробка G1/4 Blowgun includes one bling plung G1/4 Blaspistole enthält ein Stopfen G1/4 Soufflette comprend un bouchon G1/4 Pistola de soplado incluye tapon G1/4 Pistola de ar inclui tampao G1/4				
		мин.	макс.	
Температура		- 10 °C	+ 80 °C	
Давление		12 бар (1.2 МПа)		
383 Нл/мин @ 6 бар - 500 Нл/мин @ 8 бар				
81 дБ @ 6 бар				
85 дБ @ 8 бар				
Усилие на рукоятке - Force on handle Kraft am Griff - Force sur la poignée Fuerza en el mango - Força no punho			19,8 Н @ 6 бар	
Сила струи - Blowing force Kraft der Schlag - Force de soufflage Fuerza que sopla - Força de sopra			3,4 Н @ 6 бар	
2003/10/CE			Макс. 85 дБ	
OSHA 1910.95 (b)			Макс. 90 дБ 8 ч	
OSHA 1910.242 (b)			Макс. 30 PSI (2,1 бар) при блокировании	
SUVA CONFORMED				

T100 Mini



Код	Размер	Резьба	Фильтрация	Регулир.	Упак.
T100 002 231 100	FR+L 0	1/8	20 мкм	0 ÷ 8 бар	1
T100 003 231 100	FR+L 0	1/4	20 мкм	0 ÷ 8 бар	1

T100



Код	Размер
T100 205 231 100	FR+L2
T100 309 231 100	FR+L3

Резьба	Фильтрация
1/8	20 мкм
1/4	20 мкм

Регулирование	Упак.
0 ÷ 8 бар	1
0 ÷ 8 бар	1

MAN01 / MAN02

МАНОМЕТР С ОСЕВЫМ ПРИСОЕДИНЕНИЕМ

MANOMETER BACK CONNECTION
MANOMETER, ANSCHLUSS RÜCKSEITIG
MANOMÈTRE, RACCORD ARRIÈRE
CENTRÉ MANÔMETRO POSTERIOR
MANÔMETRO COM ROSCA TRASEIRA



Код	
MAN01 N2 020 000	0 ÷ 4
MAN01 N2 050 000	0 ÷ 6
MAN01 N2 060 000	0 ÷ 10
MAN01 N2 040 000	0 ÷ 12
MAN02 N2 050 000	0 ÷ 6
MAN02 N2 040 000	0 ÷ 12

2020

ДВОЙНОЙ НИППЕЛЬ РЕДУКЦИОННЫЙ

REDUCING NIPPLE (TAPER)
DOPPELNIPPEL REDUZIERT KONISCH
MAMELON DOUBLE INÉGAL, CONIQUE
MACHÓN CÓNICO DE REDUCCIÓN NIPLE
DE REDUÇÃO COM ROSCA CÔNICA



Код		
02020 00 01 AT NB	1/8	1/4
02020 00 01 3W NB	1/8	3/8
02020 00 01 4W NB	1/8	1/2
02020 00 01 7W NB	1/4	3/8
02020 00 01 8W NB	1/4	1/2
02020 00 01 AC NB	3/8	1/2
02020 00 01 AH NB	1/2	3/4
02020 00 01 AS NT	3/4	1"

2060

НИППЕЛЬ ДВОЙНОЙ РАЗЪЕМНЫЙ (3 ЭЛЕМЕНТА)

TAPER NIPPLE (3 PIECES)
DOPPELNIPPEL KONISCH EINSTELLBAR
(3 STÜCK)
MAMELON DOUBLE 3 PIÈCES
MACHÓN CÓNICO ORIENTABLE (3 PIEZAS)
NIPLE ORIENTÁVEL COM ROSCA CÔNICA
(3 PARTES)



Код	
02060 00 001	1/8
02060 00 002	1/4
02060 00 003	3/8
02060 00 004	1/2
02060 00 005	3/4
02060 00 006	1"

Без никелировки
Article not nichel-plated.
Artikel nicht vernickelt.
Article non nickelé.
Artículo no niquelado.
Item não niquelado.

2080

ФУТОРКА КОНИЧЕСКАЯ

REDUCER (TAPER)
REDUZIERUNG KONISCH
RÉDUCTION, CONIQUE
REDUCCIÓN CÓNICA
REDUÇÃO COM ROSCA CÔNICA



Код		
02080 00 01 5W NB	1/4	1/8
02080 00 01 9W NB	3/8	1/8
02080 00 01 AD NB	1/2	1/8
02080 00 01 AA NB	3/8	1/4
02080 00 01 AE NB	1/2	1/4
02080 00 01 AF NB	1/2	3/8
02080 00 01 AL NB	3/4	3/8
02080 00 01 AM NB	3/4	1/2
02080 00 01 AP NT	1"	1/2
02080 00 01 AQ NT	1"	3/4
02080 00 01 AR NT	1"1/4	1/2
02080 00 01 AU NT	1"1/4	3/4
02080 00 01 AV NT	1"1/4	1"
02080 00 01 82 NT	1"1/2	1"
02080 00 01 83 NT	2"	1"

3015

ПРОБКА С ПАРАЛЛЕЛЬНОЙ РЕЗЬБОЙ С УПЛ. КОЛЬЦОМ NBR

MALE PLUG (PARALLEL) WITH EXAGON EMBEDDED AND NBR O-RING
GEWINDESTOPFEN ZYLINDRISCH INNENSECHSKANT MIT O-RING NBR
BOUCHON À 6 PANS CREUX MÂLE, CYLINDRIQUE AVEC JOINT NBR
TAPÓN MACHO CILÍNDRICO HEXÁGONO INTERIOR CON TÓRICA NBR
TAMPÃO MACHO COM ROSCA PARALELA E SEXTAVADO INTERNO (O-RING EM NBR)



Код	
03015 00 005	M5
03015 00 001	1/8
03015 00 002	1/4
03015 00 003	3/8
03015 00 004	1/2
03015 00 006	M8x1
03015 00 007	M10x1
03015 00 008	M12x1,25
03015 00 009	3/4
03015 00 010	1"

6000

У-ОБРАЗНЫЙ СОЕДИНИТЕЛЬ 90° ПЕРЕХОДНЫЙ, 2xVP / HP

CENTRAL MALE Y 90°
Y-VERSCHRAUBUNG 90° AUSSEN-/INNENGEW.
Y ÉGAL À 90° MALE AU CENTRE
RACOR A Y 90° MACHO CENTRAL
CONEXÕES EM "Y" 90° ROSCA MACHO CENTRAL



Код	
06000 00 01 02 NB	1/8
06000 00 01 03 NB	1/4
06000 00 01 04 NB	3/8
06000 00 01 05 NB	1/2

SK010

КОМПЛЕКТ

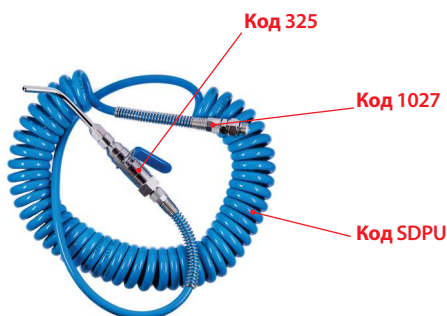

Код	Размер
SK010 08 55 05 AZ	(8-5.5) - 1/4



ISTITUTO GIORDANO s.p.a.

SPECIALISTI IN RICERCA E CERTIFICAZIONE DAL 1959

Via Rossini, 2
47814 BELLARIA (RN) Italy
Tel. ++39/0541 343030 (10 linee)
Telefax ++39/0541 345540

e-mail: istitutogiordano@giordano.it
web site: www.giordano.it

Cod. Fisc./Part. IVA: 00 549 540 409
R.E.A. c/o C.C.I.A.A. (RN) 156766
Registro Imprese Rimini n. 00549540409
Cap. Soc. € 516.000,00 i.v.

RICONOSCIMENTI UFFICIALI:

- MINISTERO LAVORI PUBBLICI: Legge 1086/71 con D.M. 27/11/82 n. 22913 "Prove sui materiali da costruzione".
- MINISTERO INDUSTRIA COMMERCIO ARTIGIANATO: D.M. 09/11/89 "Certificazione CEE per le unità da dipinto".
- MINISTERO INDUSTRIA COMMERCIO ARTIGIANATO: D.M. 31/10/91 "Certificazione CEE delle emissioni sonore di macchine da cantiere".
- MINISTERO INDUSTRIA COMMERCIO ARTIGIANATO: D.L. 27/01/92 N. 135 "Certificazione CEE delle emissioni sonore di macchine di movimento terra".
- MINISTERO INDUSTRIA COMMERCIO ARTIGIANATO: D.M. 06/07/93 "Certificazione CEE concernente la sicurezza dei giocattoli".
- MINISTERO INDUSTRIA COMMERCIO ARTIGIANATO: D.M. 30/07/97 "Certificazioni ed attestati di conformità CEE per il rendimento delle caldaie ad acqua calda alimentate con combustibili liquidi o gassosi".
- MINISTERO INDUSTRIA COMMERCIO ARTIGIANATO: Notifica n. 757890 del 15/12/98 "Certificazione CEE per gli apparecchi a gas".
- MINISTERO INDUSTRIA COMMERCIO ARTIGIANATO e MINISTERO LAVORO E PREVIDENZA SOCIALE: D.M. 09/07/93 "Certificazione CEE in materia di recipienti semplici a pressione".
- MINISTERO INDUSTRIA COMMERCIO ARTIGIANATO e MINISTERO LAVORO E PREVIDENZA SOCIALE: D.M. 04/09/94 "Certificazione CEE sulle macchine".
- MINISTERO INDUSTRIA COMMERCIO ARTIGIANATO: "Ispezioni di verifica della sicurezza e conformità dei prodotti nell'ambito della sorveglianza sul mercato e tutela del consumatore".
- MINISTERO INDUSTRIA COMMERCIO ARTIGIANATO: D.M. 02/04/98 "Rilascio di attestazioni di conformità delle caratteristiche e prestazioni energetiche dei componenti degli edifici e degli impianti".
- MINISTERO INTERNO: Legge 818/84 e D.M. 26/03/85 con autorizzazione del 21/03/86 "Prove di reazione al fuoco secondo D.M. 26/06/84".
- MINISTERO INTERNO: Legge 818/84 e D.M. 26/03/85 con autorizzazione del 10/07/86 "Prove di resistenza al fuoco secondo Circolare n. 91 del 14/09/81".
- MINISTERO INTERNO: Legge 818/84 e D.M. 26/03/85 con autorizzazione del 03/07/92 "Prove di resistenza al fuoco secondo Circolare n. 7 del 02/04/91 e norma CNVVF/CCI UNI 9723".
- MINISTERO INTERNO: Legge 818/84 e D.M. 26/03/85 con autorizzazione del 12/04/86 "Prove su estintori d'impiego portatili secondo D.M. 20/12/82".
- MURST (MINISTERO UNIVERSITÀ E RICERCA SCIENTIFICA E TECNOLOGICA): Legge 46/82 con D.M. 09/10/85 "Immissione nell'albo dei laboratori autorizzati a svolgere ricerche di carattere applicativo a favore delle piccole e medie industrie".
- MINISTERO PUBBLICA ISTRUZIONE: Protocollo n. 116 del 27/03/87 "Iscrizione allo Schedario Anagrafe Nazionale delle ricerche con codice N. ED490/93".
- SINCERT (Accreditamento Organismi Certificazione): Accredimento n. 0574 del 19/12/00 "Organismo di certificazione di sistemi qualità".
- SINAL (Sistema Nazionale per l'Accreditamento di Laboratori): Accredimento n. 0021 del 14/11/91.
- SIT (Servizio di Taratura in Italia): Accredimento n. 20 "Centro SIT di taratura per grandezze termometriche ed elettriche".
- ICM (Istituto di Certificazione Industriale per la Meccanica): "Prove di laboratorio nell'ambito degli schemi di Certificazione di Prodotto".
- IMQ (Istituto per il Marchio Qualità): "Prove di laboratorio nell'ambito degli schemi di Certificazione di Prodotto per carne umana".
- UNCSAAL (Unione Nazionale Costruttori Serramenti Alluminio Acciaio Leghe): Riconoscimento del 26/03/85 "Laboratorio per le prove di certificazione UNCSAAL su serramenti a facciate continue".
- UNI (Ente Nazionale Italiano di Unificazione - Settore Certificazione): "Prove di laboratorio nell'ambito degli schemi di Certificazione di Prodotto per termocammetti a legna con fluido a circolazione forzata e serramenti esterni".

PARTECIPAZIONI ASSOCIATIVE:

- AIA: Associazione Italiana di Acustica.
- AICARR: Associazione Italiana Condizionamento dell'Aria Riscaldamento Refrigerazione.
- AIQD: Associazione Italiana per la Qualità.
- AIPND: Associazione Italiana Prove non Distruttive.
- ALF: Associazione Laboratori Italiani Fuoco.
- ALPI: Associazione Laboratori di Prova Indipendenti.
- ASHRAE: American Society of Heating, Refrigerating and Air-Conditioning Engineers Inc.
- ASSINDUSTRIA: Associazione degli Industriali di Rimini.
- ASTM: American Society for Testing and Materials.
- ATIG: Associazione Tecnica Italiana del Gas.
- CTE: Collegio dei Tecnici Specializzati Edilizia.
- CCI: Comitato Termotecnico Italiano.
- EARMA: European Association of Research Managers and Administrators.
- EARTO: European Association of Research and Technology Organisation.
- EGOLF: European Group of Official Laboratories for Fire Testing.
- UNI: Ente Nazionale Italiano di Unificazione.

CLAUSOLE

Il presente documento si riferisce solamente al campione o materiale sottoposto a prova.
"Il presente documento non può essere riprodotto parzialmente, salvo approvazione scritta del laboratorio".

ABRIDGED TEST REPORT No. 189470

(Refers to test report No. 189076 issued by this Institute on 26/10/2004)

Place and date of issue: Bellaria, 08/11/2004

Customer: AIGNEP S.p.A. - Via Industriale n. 1 - 25070 BIONE (BS)

Date test requested: 13/09/2004

Order number and date: 26665, 14/09/2004

Date specimen received: 13/09/2004

Date test effected: from 11/10/2004 to 15/10/2004

Purpose of test: Testing copper-alloy quick-action couplings for use with aluminium tubes

Test site: Istituto Giordano S.p.A. - Blocco 1 - Via Rossini, 2 - 47814 Bellaria (RN)

Specimen origin: supplied by Customer

Identification of specimen received: No. 2004/1522

Description of specimen

The test specimens are known as "Raccordi ad innesto rapido per tubazioni in alluminio Serie 90.000".

Result of test

The tests listed below, agreed with the Customer and, in the absence of specific standards, conducted in accordance with standard UNI EN 1254-2: 2000, gave the following results:

- Leaktightness under internal pneumatic pressure: No visible signs of leakage;
- bursting strength test: DN 20: 115 bar, DN 25: 75 bar, DN 32: 78 bar, DN 40: 75 bar, DN 50: 58 bar and DN 63: 62 bar;
- resistance to pull-out: maximum axial movement 0,9 mm and no visible leakage in the subsequent pneumatic pressure test;
- leaktightness under internal pneumatic pressure whilst subjected to bending: no visible signs of leakage or damage.

As regards the description of the specimen, normative references, test methods, test equipment, test results and everything else necessary for the identification of the work carried out, please see Test Report No. 189076 issued by this Institute on 26/10/2004.

Test Technician (Per. Ind. Walter Frattini) Laboratory Manager, Applied Physics (Dott. Ing. Vincenzo Iommi) Chairman or Managing Director (Dott. Ing. Vincenzo Iommi)

Comp. AV Revis	This abridged report consists of 1 sheet This document is the English translation of the abridged test report No. 189470 of 08/11/2004 issued in Italian. Date of translation: 29/11/2004.	Sheet 1 of 1
-------------------	--	-----------------



Istituto Giordano S.p.A.
 Via Rossini, 2 - 47814 Bellaria-Igea Marina (RN) - Italia
 Tel. +39 0541 343030 - Fax +39 0541 345540
 istitutogiordano@giordano.it - www.giordano.it
 PEC: ist-giordano@legalmail.it
 Cod. Fisc./Part. IVA: 00 549 540 409 - Cap. Soc. € 1.500.000 i.v.
 R.E.A. c/o C.C.I.A.A. (RN) 156766
 Registro Imprese di Rimini n. 00 549 540 409

СОКРАЩЕННЫЙ ПРОТОКОЛ ИСПЫТАНИЙ № 317262 (к протоколу № 316851, выпущенному Институтом Джордано 25/06/2014)

Место и дата выпуска: Bellaria-Igea Marina - Италия, 11/07/2014
Заказчик: AIGNEP S.p.A. - Via Don Giuseppe Bazzoli, 34 - 25070 БИОНЕ (BS) - Италия
Заявленная дата испытаний: 20/03/2014
Номер заказа и дата: 62619, 24/03/2014
Дата предоставления образца на испытания: 23/04/2014
Период проведения испытаний: от 05/06/2014 до 24/06/2014
Цель испытаний: испытание быстродействующих соединений алюминиевых трубопроводов
Место проведения: Istituto Giordano S.p.A. - Blocco 1 - Via Rossini, 2 - 47814 Bellaria-Igea Marina (RN) - Италия
Происхождение образца: отобран и представлен Заказчиком
Идентификация образца: № 2014/0843

Наименование и описание образца*

Представленные образцы называются "Серия 90.000, DN80 быстродействующие соединения для применения с алюминиевыми трубами". Основные элементы образцов:

- алюминиевая гайка с обработанной поверхностью;
- уплотнительное кольцо NBR;
- алюминиевый корпус с обработанной поверхностью;
- удерживающее кольцо из технической смолы;
- цапга из нержавеющей стали AISI 301;
- направляющее кольцо трубы из технической смолы;
- самоконтрящаяся гайка из оцинкованной стали;
- винт из оцинкованной стали с головкой с внутренним шестигранником. Заявленное Заказчиком максимальное давление 16 бар.

Результат испытаний

Представленный Заказчиком образец был подвергнут следующим испытаниям со следующими результатами:

- герметичность под давлением воздуха положительным (24 и 0,5 бар)/отрицательным (0,9 бар)
РЕЗУЛЬТАТ ИСПЫТАНИЯ: ПРОЙДЕНО;
- испытание давлением на механическую прочность
РЕЗУЛЬТАТ ИСПЫТАНИЯ: небольшая утечка из-под втулки одного из фитингов под давлением 64 бар (ПРОЙДЕНО);
- сопротивление выбиванию трубы
РЕЗУЛЬТАТ ИСПЫТАНИЯ: ПРОЙДЕНО;
- герметичность под давлением жидкости с одновременным изгибом
РЕЗУЛЬТАТ ИСПЫТАНИЯ: ПРОЙДЕНО.

По образцам, испытательным сборкам, нормативным ссылкам, методиками испытаний, испытательному оборудованию, детальным результатам испытаний и всему прочему, что касается испытаний, проведенной работе по идентификации образцов просим смотреть протокол № 316851, составленный Институтом Джордано 25/06/2014.

(*) В соответствии с данными Заказчика.

Оператор испытаний:
д-р тех. наук Антоньетта Серра

Руководитель лаборатории прикладной физики:
д-р тех. наук Винченцо Иомми

Исполнительный Директор
(Dott. Arch. Sara Lorenza Giordano)
(д-р архит. Сара Лоренца Джордано)



Firmato digitalmente da SARA LORENZA GIORDANO

Оригинал настоящего документа состоит из электронного документа, скрепленного цифровой подписью, в соответствии с DPR (Президентским Декретом) 513/97.

Сост. AV
Пров. AS

Настоящий сокращенный протокол оформлен на 1 листе.
Настоящий документ является переводом на английский язык сокращенного протокола № 317262 от 11/07/2014 на итальянском языке; в случае возникновения спорных вопросов действительной является исключительно итальянская версия. Дата перевода: 06/06/2017.

Лист
1 из 1

ОГОВОРКА: Настоящий документ касается только представленного на испытания образца, запрещается его частичное воспроизведение без письменного разрешения Института Джордано.



Istituto Giordano S.p.A.
 Via Rossini, 2 - 47814 Bellaria (RN) Italy
 Tel. +39 0541 343030 - Fax +39 0541 345540
 istitutogiordano@giordano.it - www.giordano.it
 Cod. Fisc./P.Iva 00 549 540 409 - Cap. Soc. € 880.000 i.v.
 R.E.A. c/o C.C.I.A.A. (RN) 156766
 Registro Imprese di Rimini n. 00 549 540 409
 Organismo Europeo notificato n. 0407
 Accreditamenti: SINCERT (057A e 082B) - SIT (20)

RICONOSCIMENTI UFFICIALI MINISTERI ITALIANI:

- Legge 1086/71 con D.M. 27/11/82 n. 22913 "Prove sui materiali da costruzione".
- D.M. 09/11/99 "Certificazione CE per le unità da diporto".
- D.M. 04/08/94 "Certificazione CEE sulle macchine".
- Notifica n. 757890 del 15/12/98 "Certificazione CEE per gli apparecchi a gas".
- D.M. 09/07/93 "Certificazione CEE in materia di recipienti semplici a pressione".
- D.M. 08/07/93 "Certificazione CEE concernente la sicurezza dei giocattoli".
- Incarichi di verifica della sicurezza e conformità dei prodotti nell'ambito della sorveglianza sul mercato e tutela del consumatore.
- D.M. 02/04/98 "Rilascio di attestazioni di conformità delle caratteristiche e prestazioni energetiche dei componenti degli edifici e degli impianti".
- Legge 818/84 e D.M. 26/03/85 con autorizzazione del 21/03/86 "Prove di reazione al fuoco secondo D.M. 26/06/84".
- Legge 818/84 e D.M. 26/03/85 con autorizzazione del 10/07/86 "Prove di resistenza al fuoco secondo Circolare n. 91 del 14/09/81".
- Legge 818/84 e D.M. 26/03/85 con autorizzazione del 03/07/92 "Prove di resistenza al fuoco secondo Circolare n. 7 del 02/04/91 norma CNVVF/CCI UNI 9723".
- Legge 818/84 e D.M. 26/03/85 con autorizzazione del 12/04/88 "Prove su estintori d'incendio portatili secondo D.M. 20/12/82".
- Legge 46/82 con D.M. 09/10/85 "Immissione nell'albo dei laboratori autorizzati a svolgere ricerche di carattere applicativo a favore delle piccole e medie industrie".
- Protocollo n. 116 del 27/03/87 "Iscrizione allo Schedario Anagrafe Nazionale delle ricerche con codice N.E0490Y9Y".
- Decreto 24/05/02 "Certificazione CE di rispondenza della conformità delle attrezzature a pressione".
- Decreto 14/02/02 "Certificazione CE di conformità in materia di emissione acustica ambientale per macchine e attrezzature".
- Decreto 05/02/03 "Esecuzione delle procedure di valutazione della conformità dell'equipaggiamento marittimo".
- G.U.R.I. n. 236 del 07/10/04 "Certificazione CE sugli ascensori".
- Notifica per le attività di attestazione della conformità alle norme armonizzate della Direttiva 89/106 sui prodotti da costruzione.

ENTI TERZI:

- SINCERT: Accreditamenti n. 057A del 19/12/00 "Organismo di certificazione di sistemi di gestione per la qualità" e n. 082B del 12/04/06 "Organismo di certificazione di prodotto".
- SIT: Centro multisede n. 20 (Bellaria - Pomezia) per grandezze termometriche ed elettriche.
- ICIM: "Prove di laboratorio nell'ambito degli schemi di Certificazione di Prodotto".
- IMQ: "Prove di laboratorio nell'ambito degli schemi di Certificazione di Prodotto per canne fumarie".
- UNCSAAL: Riconoscimento del 26/03/85 "Laboratorio per le prove di certificazione UNCSAAL su serramenti e facciate continue".
- IMQ-UNI: "Prove di laboratorio nell'ambito degli schemi di Certificazione di Prodotto per termocammetti a legna con fluido a circolazione forzata".
- CSI-UNI: "Prove di laboratorio in ambito degli schemi di Certificazione di Prodotto per serramenti esterni".
- KEYMARK per isolanti termici: "Misure di conduttività termica per materiali isolanti".
- IFI: "Prove di laboratorio e sorveglianza in azienda nell'ambito degli schemi di Certificazione di Prodotto per porte, finestre, chiusure oscuranti (antileffrazione) e serramenti".
- EFSG: "Prove di laboratorio su casseforti e altri mezzi di custodia".
- AENOR: "Valutazione della conformità ai fini della marcatura CE per alcuni prodotti inerenti la direttiva prodotti da costruzione".
- VTT-Finlandia: "Valutazione della conformità ai fini della marcatura CE per alcuni prodotti inerenti la direttiva prodotti da costruzione".
- C.C.I.A.A. Rimini: 28/01/04 "Verifica periodica dell'affidabilità metrologica di strumenti metrici in materia di commercio".

PARTECIPAZIONI ASSOCIATIVE:

- AIA: Associazione Italiana di Acustica.
- AICARR: Associazione Italiana Condizionamento dell'Aria Riscaldamento Refrigerazione.
- AICQ: Associazione Italiana per la Qualità.
- AIPnD: Associazione Italiana Prove non Distruttive.
- ALIF: Associazioni Laboratori Italiani Fuoco.
- ALPI: Associazione Laboratori di Prova Indipendenti.
- ASHRAE: American Society of Heating, Refrigerating and Air-Conditioning Engineers Inc.
- ASTM: American Society for Testing and Materials.
- ATIG: Associazione Tecnica Italiana del Gas.
- CTE: Collegio dei Tecnici della Industrializzazione Edilizia.
- CTI: Comitato Termotecnico Italiano.
- EARMA: European Association of Research Managers and Administrators.
- EARTO: European Association of Research and Technology Organisation.
- EGOLF: European Group of Official Laboratories for Fire Testing.
- UNI: Ente Nazionale Italiano di Unificazione.

CLAUSOLE:

Il presente documento si riferisce solamente al campione o materiale sottoposto a prova.
 Il presente documento non può essere riprodotto parzialmente, salvo approvazione scritta del laboratorio.

ABRIDGED TEST REPORT No. 238763

(Refers to test report No. 236272 issued by this Institute on 07/02/2008)

Place and date of issue: Bellaria-Igea Marina - Italy, 07/04/2008

Customer: AIGNEP S.p.A. - Via Industriale, 1 - 25070 BIONE (BS) - Italy

Date test requested: 09/11/2007

Order number and date: 39092, 09/11/2007

Date specimen received: 20/11/2007

Date test effected: from 20/12/2007 to 08/01/2008

Purpose of test: Testing copper-alloy quick-action couplings for use with aluminium tubes

Test site: Istituto Giordano S.p.A. - Blocco 1 - Via Rossini, 2 - 47814 Bellaria-Igea Marina (RN) - Italy

Specimen origin: sampled and supplied by Customer

Identification of specimen received: No. 2007/2505

Description of specimen

The test specimens are known as "Raccordi ad innesto rapido per tubazioni in alluminio Serie 90.000" ("Copper-alloy quick-action couplings for use with aluminium tubes Series 90.000"), DN 110.

Result of test

The tests listed below, agreed with the Customer and, in the absence of specific standards, conducted in accordance with standard UNI EN 1254-2:2000, gave the following results:

- leaktightness under internal pneumatic pressure: No visible signs of leakage;
- bursting strength test: 51 bar;
- resistance to pull-out: maximum axial movement 0,49 mm and no visible leakage in the subsequent pneumatic pressure test;
- leaktightness under internal hydraulic pressure whilst subjected to bending: no visible signs of leakage or damage.

As regards the description of the specimen, normative references, test methods, test equipment, test results and everything else necessary for the identification of the work carried out, please see Test Report No. 236272 issued by this Institute on 07/02/2008.

Test Technician
 (Per. Ind. Walter Fratti)

Manager, Applied Physics
 Laboratory
 (Dott. Ing. Vincenzo Iommi)

Chairman or
 Managing Director

Dott. Ing. Vincenzo Iommi

Comp. AV
 Revis:

This abridged report consists of 1 sheet
 This document is the English translation of the abridged test report No. 238763 of 07/04/2008 issued in Italian.
 Date of translation: 07/04/2008.

Sheet
 1 of 1

ВЫДЕРЖКИ ИЗ ПРОТОКОЛОВ ИСПЫТАНИЙ № 189076, № 236272 И № 312056 ИНСТИТУТА ДЖОРДАНО

OUTCOME OF THE TEST NR.189076, NR. 236272 AND N° 312056 OF GIORDANO INSTITUTE

AUSZÜGE VON TESTERGEBNISSEN NR.° 189076, NR.° 236272 UND NR.° 312056 VOM INSTITUT GIORDANO

EXTRAITS DES RÉSULTATS DES TESTS NO189076, NO 236272 ET NO 312056 DE L'INSTITUT GIORDANO

Resultados de la prueba NR. NR.189076, NR. 236272 y N° 312056 de GIORDANO INSTITUTE

RESULTADOS EXTRAÍDOS DO RELATÓRIO DE TESTE N° 189076 E N° 236272 DO INSTITUTO GIORDANO

Испытание	RU
Испытательное давление в 1,5 раза выше заявленного максимального рабочего давления.	
Test	GB
Test of pressure 1.5 time higher of the max declared.	
Test	DE
Prüfdruck um 1,5 Mal höher als der angegebene maximale Betriebsdruck.	
Test	FR
Contrôle d'étanchéité à une pression 1,5 fois supérieur de la pression nominale et à 0,5 bar.	
Test	ES
Prueba de presión 1.5 veces más elevadas del máximo declarado.	
Teste	PT
Teste de pressão 1,5 vez maior do que a pressão máxima declarada.	

DN	Исп. давление 22,5 бар (воздух, 1,5 PN) в течение 15 мин	Исп. давление воздуха 0,5 бар при 15 мин
		Pneumatic resistance at 22,5 bar (1,5 PN) for 15 min Pneumatische Beständigkeit bei 22,5 bar (1,5 PN) für 15 Minuten Résistance pneumatique à 22,5 bar (1,5 PN) pour 15 minute Resistencia neumática a 22,5 bar (1,5 PN) por 15 min Resistência pneumática a 22,5 bar (1,5 PN) por 15 minutos
20	Без видимой утечки No visible leakage Kein erkennbarer Verlust Aucune fuite No fugas visibles Nenhuma perda ou vazamento visível	
25		
32		
40		
50		
63		
80		
110		

Испытание	IT
Прочность на растяжение при постоянной нагрузке по UNI-EN 1254-2:2000 п. 5.5.	
Test	GB
Constant tensile stress in accordance with Norma UNI-EN 1254-2:2000 point 5.5.	
Test	DE
Zugversuche nach konstanter Belastung nach Norm: UNI-EN 1254-2:2000 Punkt 5.5.	
Test	FR
Essais de traction à charge constante selon la norme: UNI-EN 1254-2:2000 section 5.5.	
Test	ES
Prueba de tensión según norma UNI-EN 1254-2:2000 punto 5.5.	
Teste	PT
Testes de tração constante segundo a Norma UNI-EN 1254-2:2000 ponto 5.5.	

DN	Испытательное тяговое усилие	Выход трубы из соединения	Исп. давление воздуха 6 бар
		Power of stress Angewendete Zugkraft Force de traction Potencia de tension Força aplicada	Unthreading of tubes Extraktion des Rohres aus der Verschraubung Extraction du tube Tubos sin rosca Desconexão máxima entre conexões e tubo
	(Н)	(мм)	
20	1500	0.9	Без видимой утечки No visible leakage Kein erkennbarer Verlust Aucune fuite No fugas visibles Nenhuma perda ou vazamento visível
25			
32			
40			
50			
63			
80			
110			

Испытание	RU	Давление разрушения жидкостное
Давление разрушения		DN Hydraulic pressure of breaking Hydraulischer Berstdruck Pression hydraulique d'éclatement Presión hidráulica de rotura Pressão hidráulica de ruptura
Test:	GB	
Pressure of explosion.		
Test	DE	
Überprüfen des Berstdruckes.		
Test	FR	
Contrôle de la pression d'éclatement.		
Test	ES	
Presión de explosión.		
Teste	PT	
Teste de pressão de ruptura.		
	20	При давлении 115 бар произошло частичное вытягивание трубного соединения с существенной потерей среды. Pressure 115 bar unthreading of a fitting from the tube with leakage. Bei einem Druck von 115 bar gab es einen teilweisen Auszug der Rohrverbindung, mit einer signifikanten Verlustmenge. A une pression de 115 bars, extraction partielle du tube et pertes notables. Presión 115 bar: el tubo comienza a salir de las conexiones con fugas. A uma pressão de 115 bar houve uma parcial desconexão do tubo com a conexão causando um vazamento ar perceptível.
	25	При давлении 75 бар труба выдавливается из трубного соединения. Complete unthreading pressure 75 bar of a tube. Bei einem Druck von 75 bar erfolgt die Trennung zwischen Rohr und Verschraubung. Déconnexion du tube à une pression de 75 bar. Presión 75 bar: el tubo sale completamente de las conexiones. A uma pressão de 75 bar houve uma desconexão total do tubo com a conexão.
	32	При давлении 78 произошло частичное отсоединение трубы от трубного соединения, при давлении 93 бар произошло полное отделение отделеия. At 78 bar unthreading of a tube with wetseal: at 93 total unthreading. Bei einem Druck von 78 bar entstand eine teilweise Extraktion der Rohrverbindung, bei 93 bar eine komplette Trennung Extraction partielle du tube du raccord à 78 bar, déconnexion à 93 bar. Presión 78 bar: el tubo sale de las conexiones con juntas mojadas. 93 bar desconexión total. A uma pressão de 78 bar iniciou-se a desconexão do tubo com uma das conexões estanques; a 93 bar ocorreu total desconexão do tubo.
	40	При давлении 75 бар произошло разделение соединения при значительной потере среды. At 75 bar the tube becomes unthreaded while trying to increase the pressure. Vorzeitige Extraktion der Rohrverbindung bei 75 bar und grosse Verluste. Début d'extraction du tube du raccord à 75 bar et pertes notables. Presión 75 bar: el tubo comienza a salir de las conexiones con fugas. A uma pressão de 75 bar o tubo começou a se desconectar da conexão enquanto a pressão estava sendo incrementada.
	50	При давлении 58 бар произошло разделение соединения с большой потерей среды: поэтому дальнейшее повышение давления признано невозможным. At 58 bar the tube has become unthreaded. Vorzeitige Extraktion der Rohrverbindung bei 58 bar und grosse Verluste, daher keine Anhebung des Druckes möglich Début d'extraction du tube du raccord à 58 bar et pertes notables. Presión 58 bar: el tubo sale completamente de las conexiones A uma pressão de 58 bar o tubo começou a se desconectar de uma das conexões a desconexão progressiva e as perdas não permitiram aumentar mais a pressão.
	63	При давлении 58 бар произошло разделение соединения с большой потерей среды: поэтому дальнейшее повышение давления признано невозможным. At 58 bar the tube has become unthreaded. Vorzeitige Extraktion der Rohrverbindung bei 58 bar und grosse Verluste, daher keine Anhebung des Druckes möglich Début d'extraction du tube du raccord à 58 bar et pertes notables. Presión 58 bar: el tubo sale completamente de las conexiones A uma pressão de 58 bar o tubo começou a se desconectar de uma das conexões a desconexão progressiva e as perdas não permitiram aumentar mais a pressão.
	80	При давлении 64 бар утечка, дальнейшее повышение давления не возможно. At 64 bar, leakage. Bei 64 bar Leckagen, keine Möglichkeit den Druck zu erhöhen. A 64 bar, pertes empêchant de poursuivre le test. Presión 64 bar: fugas. A uma pressão de 64 bar foi verificado um vazamento.
	110	При давлении 36 бар утечка, дальнейшее повышение давления не возможно. At 36 bar, leakage. Bei 36 bar Leckagen, keine Möglichkeit den Druck zu erhöhen. A 36 bar, pertes empêchant de poursuivre le test. Presión 36 bar: fugas. A uma pressão de 36 bar foi verificado um vazamento.

Испытание	RU
Проверка герметичности по воздуху при одновременном приложении изгибающего усилия в соответствии с UNI-EN 1254-2:2000 п. 5.6.	
Test	GB
Resistance under pneumatic internal pressure and bending stress at the same time according to Norma UNI-EN 1254-2:2000 point 5.6.	
Test	DE
Prüfen der Dichtheit unter gleichzeitiger Anwendung von Biegespannung nach Norm: UNI-EN 1254-2:2000 Punkt 5.6.	
Test	FR
Contrôle d'étanchéité sous contraintes de flexion selon la norme : UNI-EN 1254-2:2000 section 5.6	
Test	ES
Resistencia bajo presión neumática interna y carga de flexión al mismo tiempo según norma UNI-EN 1254-2:2000 punto 5.6. Distancia entre puntos de flexion.	
Teste	PT
Resistência sob pressão pneumática interna e flexão da tubulação de acordo com a Norma UNI-EN 1254-2:2000 ponto 5.6.	

DN	Расстояние между точками опоры <i>Distance between bearing points Der Abstand zwischen den Stützpunkten Distance entre les points d'appuis Distancia entre puntos de flexion Distância entre os centros dos suportes montados</i>	Испытательное давление воздуха <i>Pneumatic pressure Pneumatischer Prüfdruck Pression pneumatique Presión neumática Pressão pneumática interna de teste</i>	Испытание на механическую прочность и герметичность <i>Resistance and pneumatic stamina Prüfen der mechanischen Festigkeit und Dichtheit Résistance et endurance pneumatique Resistencia neumática y física Verificação da resistência mecânica e vedação contra vazamento</i>
	(мм)	(бар)	
20	1800	10	Без видимой утечки <i>No visible leakage Kein erkennbarer Verlust Aucune fuite No fugas visíveis Nenhuma perda ou vazamento visível</i>
25	1800	10	
32	1800	10	
40	2400	10	
50	2700	10	
63	3000	6	
80	3000	6	
110	3000	6	

Полный протокол предоставляется по запросу.

*The certificate is available upon request.
Der vollständige Bericht ist auf Anfrage erhältlich.
Le rapport complet est disponible sur demande.
El certificado está disponible bajo demanda.
O certificado está disponível a pedido.*

ДЕКЛАРАЦИЯ СООТВЕТСТВИЯ НА СИСТЕМУ РАСПРЕДЕЛЕНИЯ СЖАТОГО ВОЗДУХА

CONFORMITY DECLARATION FOR THE DISTRIBUTION OF COMPRESSED-AIR
 KONFORMITÄTSEKTLÄRUNG FÜR DIE DRUCKLUFTVERTEILUNG
 DÉCLARATION DE CONFORMITÉ - DISTRIBUTION D'AIR COMPRIMÉ
 DECLARACIÓN DE CONFORMIDAD PARA REDES DE AIRE COMPRIMIDO
 DECLARAÇÃO DE CONFORMIDADE PARA REDE DE DISTRIBUIÇÃO DE AR COMPRIMIDO

RU

Мы подтверждаем, что система распределения воздуха соответствует следующим условиям работы

- давление -0,99÷16 бар
- температура -20°C÷ 80 °C

в соответствии с Директивой 2014/68/UE (PED: Директива по Оборудованию под Давлением)

GB

We declare that the system used with pressure 0.99÷16 bar and temperature -20°C÷ 80 °C with directive 2014/68/UE (PED: Pressure Equipment Directive).

DE

Wir bestätigen, dass das Luftverteilungssystem zu den folgenden Nutzungsbedingungen:
 Druck -0,99 bis 16 bar / Temperatur -20°C bis 80 °C die Richtlinie 2014/68/UE (PED: Pressure Equipment Directive / Druckgeräterichtlinie) erfüllt.

FR

Nous déclarons que le système utilisé entre -0,99 et 16 bar de pression, dans une plage de température de -20°C à 80°C répond à la Directive 2014/68/UE (directive des équipements sous pression).

ES

Declaramos que el sistema utilizado a presión 0.99÷16 bar y temperatura -20°C÷ 80 °C es conforme a la Directiva 2014/68/UE (PED: Pressure Equipment Directive).

PT

Declaramos que o sistema de redes de distribuição de ar comprimido, utilizado nas seguintes condizioni de trabalho: pressão -0,99 ~ 15 bar e temperatura -20°C ~ 80 °C satisfaz a diretiva 2014/68/UE (PED: Pressure Equipment Directive).

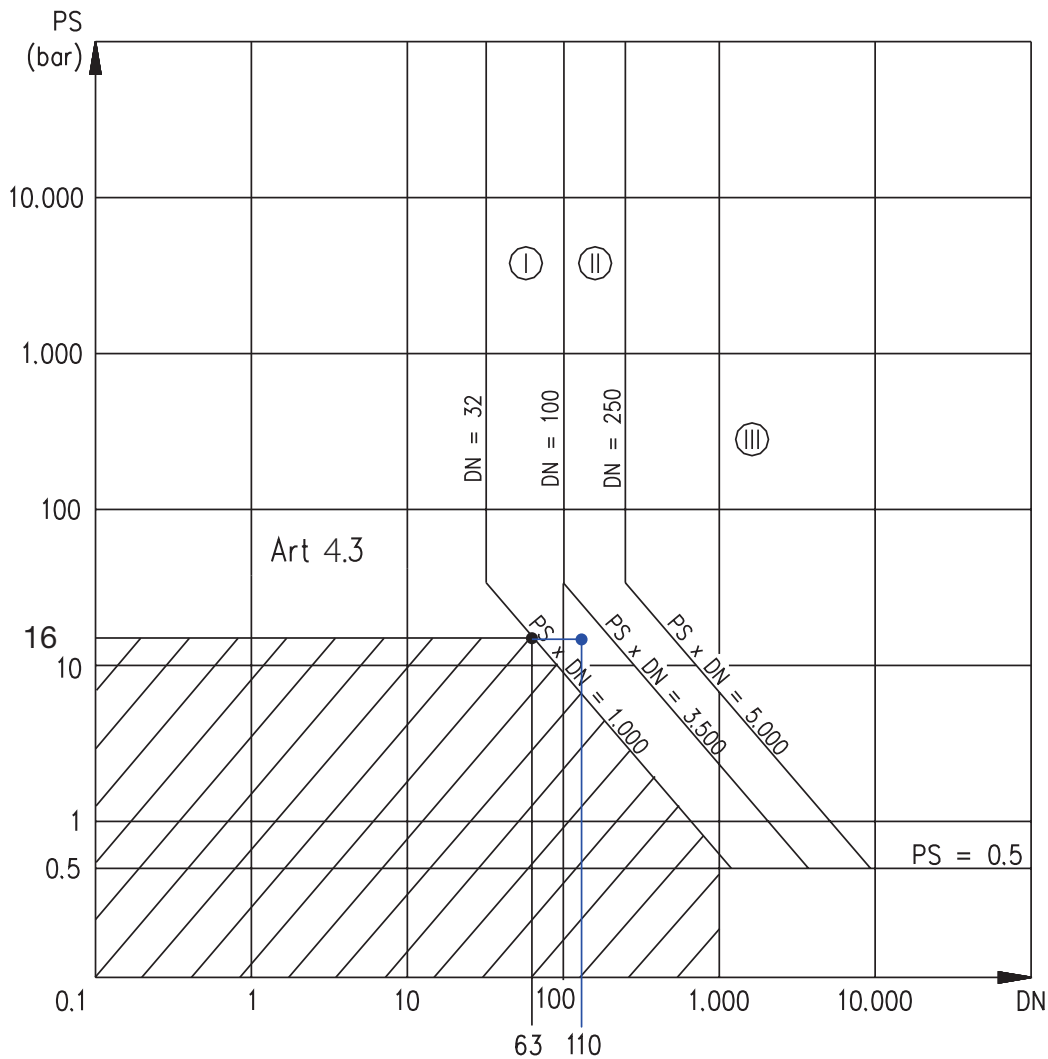

RU

На графике видно, что при диаметре 63 и максимальном давлении 16 бар точка пересечения PS x DN=16x59= 944 находится с левой стороны зоны PS x DN= 1.000: это означает в зоне, не подлежащей маркировке CEE в соответствии с указанной выше директивой (Ст. 4.3).

Поэтому, на основании Директивы 2014/68/UE Ст. 4.3 ни для труб, ни для фитингов (Ø20-Ø25-Ø32-Ø40-Ø50- Ø63) маркировка в соответствии с CEE не требуется. Что касается диаметров DN 80, DN110 при максимальном давлении 16 бар точка пересечения (PS X DN = 16x76 = 1216 для DN80) и (PS X DN = 16x105 = 1680 для DN110) находятся на графике выше в зоне, обозначенной как "Категория I".

В соответствии с Директивой 2014/68/UE, для этой области требуется оценка соответствия на заводе-изготовителе.

GB

Considering the internal diameter for DN63 and max pressure 16 bar, on can see on the graphic that the intersection point PS x DN=16x59= 944 is on the left side of zone PS x DN= 1.000: it meas is exempt from CEE marking according to the above mentioned directive (Art.4.3). Therefore all tubes and fitting (Ø20-Ø25-Ø32-Ø40-Ø50- Ø63) do not require any CEE marking.

Considering the internal diameter for DN80, DN110 and maximum pressure of 16 bar, the intersection point (PS X DN = 16x76 = 1216 for DN80) and (PS X DN = 16x105 = 1680 for DN 110) in the chart above, is in the area called "CATEGORIA I".

According to Directive 2014/68/UE this area has a conformity evaluation made at factory.

DE

Auf der Grafik kann man sehen, dass beim Durchmesser 63 und Maximaldruck von 16 bar der Schnittpunkt PS x DN=59x16= 944 auf der linken Seite der Zone PS x DN= 1.000 liegt: das bedeutet in der CEE-Kennzeichnung freien Zone, gemäss der oben genannten Richtlinie (Art.4.3).

Deshalb benötigt keines der Rohre oder der Verschraubungen (Ø20-Ø25-Ø32-Ø40-Ø50- Ø63) eine CEE-Markierung.

Was den Durchmesser 80 und 110 bei einem Maximaldruck von 16 bar betrifft, liegen die Schnittpunkte PS X DN = 76x16= 1216 und 105x16 = 1680 auf der obenstehenden Grafik in der "CATEGORIA I" genannten Zone. Gemäss der Richtlinie 2014/68/UE muss in diesem Bereich eine Konformitätsbewertung im Werk gemacht werden.

FR

Si nous considérons dans le graphique ci-dessus le diamètre interne du tube de Ø63 mm et la pression maximale de 16 bar, le point d'intersection PS x DN = 59x16 = 944 se situe sur le côté gauche de la zone PS x DN = 1.000. Par conséquent, tous les tubes et les raccords du système de distribution d'air Infinity (Ø20-Ø25-Ø32-Ø40-Ø50-Ø63) ne nécessitent pas de marquage CEE selon la directive 2014/68/UE (Art. 4.3).

Considérant les diamètres internes des tubes de Ø80 mm et Ø110 mm ainsi que la pression maximale de 16 bar, les points d'intersections PS x DN = 105x16 = 1680 et 76x16=1216 se situent dans le tableau ci-dessus dans la zone appelée "CATEGORIE I".

Pour cette catégorie, la directive 2014/68/UE prévoit une évaluation de la conformité, selon un contrôle interne.

ES

Considerando el diámetro interno DN63 y la presión máxima 16 bar, en el gráfico el punto de intersección PS x DN=16x59= 944 está en el lado izquierdo PS x DN= equivalente a artículos exentos d "Marca CE" según norma indicada antes (Art. 4.3).

Por consiguiente tubos y conexiones (Ø20-Ø25-Ø32-Ø40-Ø50- Ø63) no necesitan la "Marca CE".

Considerando el diámetro interno DN80, DN110 y la presión máxima 16 bar, en el gráfico el punto de intersección (PS x DN=16x76= 1216 por DN80) y (PS X DN = 16x105 = 1680 for DN 110) está en el area "CATEGORIA I". Según norma 2014/68/UE esta area permite una evaluación de conformidad basada en controles a nivel de fábrica.

PT

Levando em consideração o diâmetro de 63mm e a pressão máxima de 15 bar, se observa no gráfico, que o ponto de intersecção PS x DN=63x15= 945 está à esquerda da zona PS x DN= 1.000: zona isenta de marcação CE segundo a diretiva mencionada (Art.4.3).

Desta forma com base na diretiva 2014/68/UE Art. 4.3 para todos os tubos e conexões relacionadas (Ø20-Ø25-Ø32-Ø40-Ø50- Ø63) não é necessária a marcação CE.

Levando em consideração o diâmetro 110mm e a pressão máxima de 15 bar, se observa no gráfico, que o ponto de intersecção PS X DN = 110x15 = 1650 está na zona chamada de "Categoria I".

Com base na diretiva 2014/68/UE para tal zona, é prevista uma verificação de conformidade executada através de um controle de fabricação executado na fábrica.

СООТВЕТСТВИЕ ПОЛИЭФИРНОГО ПОРОШКОВОГО ПОКРЫТИЯ АЛЮМИНИЕВЫХ ТРУБ INFINITY

CONFORMITY OF POLYESTER POWDER PAINTING ON ALUMINIUM TUBES OF SERIE INFINITY
 KONFORMITÄT VON POLYESTER-PULVERBESCHICHTUNG AUF INFINITY-ALUMINIUMROHREN
 CONFORMITÉ DE LA PEINTURE POLYESTER DES TUBES EN ALUMINIUM DE LA SÉRIE INFINITY
 TUBOS ALUMINIO INFINITY REVESTIDOS CON PINTURA DE POLIÉSTER PULVERIZADA CONFORME.
 CONFORMIDADE DO PROCESSO DE PINTURA A PÓ (POLIÉSTER) NOS TUBOS DE ALUMÍNIO DA SÉRIE INFINITY

<p>Подготовка RU</p> <p>Гарантирует высокую адгезию краски и предотвращает коррозию и окисление окрашенных поверхностей. Соответствует следующей нормативной документации: UNI 9921 - DIN 50939 - ASTM D 1730 - MIL C 5541</p> <p>Покраска</p> <p>С применением сертифицированных как нетоксичные полиэфирных порошковых покрытий QUALICOT и GSB в соответствии со следующей нормативной документацией: UNI 9983 - BS 6496 - AAMA 603-605</p> <p>Такая обработка защищает внешнюю поверхность труб от коррозии. Внутренняя поверхность трубы хромированная.</p>	<p>Pre-Treatment GB</p> <p><i>It guarantees the anchorage of the painting to the tube and prevents corrosion and oxydation of not painted parts according to:</i> UNI 9921 - DIN 50939 - ASTM D 1730 - MIL C 5541</p> <p>Painting</p> <p><i>Made using powder painting not-toxic certified QUALICOT and GSB according to:</i></p> <p>UNI 9983 - BS 6496 - AAMA 603-605</p> <p><i>The above mentioned treatments prevents corrosion to external part. Inside is treated with chrome.</i></p>	<p>Vorbehandlung DE</p> <p><i>Sie garantiert die Haftung der Farbe und verhindert Korrosion und Oxidation der lackierten Teile. Erfüllt folgende Normen:</i> UNI 9921 - DIN 50939 - ASTM D 1730 - MIL C 5541</p> <p>Lackierung</p> <p><i>Unter Verwendung einer als ungiftig zertifizierten QUALICOT und GSB Polyester-Pulverbeschichtung, konform zu den folgenden Standards:</i></p> <p>UNI 9983 - BS 6496 - AAMA 603-605</p> <p><i>Die oben genannte Behandlung schützt die Aussenseite des Rohres vor Korrosion. Die Innenseite ist mit Chrom behandelt.</i></p>
<p>Prétraitement FR</p> <p><i>Il assure l'ancrage de la peinture et empêche la corrosion et l'oxydation des parties non peintes. Répond aux normes:</i> UNI 9921 - DIN 50939 - ASTM D 1730 - MIL C 5541</p> <p>Peinture</p> <p><i>La peinture est fabriquée à l'aide de poudre polyester non toxique QUALICOT certifié Selon GSB:</i></p> <p>UNI 9983 - BS 6496 - AAMA 603-605</p> <p><i>Le traitement qui recouvre entièrement les tubes, les rend résistants à la corrosion dans des environnements marins. L'intérieur étant prétraité, celui-ci est protégé de manière optimale.</i></p>	<p>Pretratamiento ES</p> <p><i>Garantiza la adherencia de la pintura y previene la corrosión o oxidación de partes sin cobertura, según</i> UNI 9921 - DIN 50939 - ASTM D 1730 - MIL C 5541</p> <p>Pintura</p> <p><i>La pintura es en polvo no toxica, certificada QUALICOT y GSB según:</i></p> <p>UNI 9983 - BS 6496 - AAMA 603-605</p> <p><i>Esta pintura previene la corrosión de la parte exterior. Internamente es tratado con cromo.</i></p>	<p>Pré-tratamento PT</p> <p><i>Garante a fixação da tinta no alumínio e a também previne a corrosão e a oxidação das peças não pintadas garantindo a conformidade com as normas técnicas:</i> UNI 9921 - DIN 50939 - ASTM D 1730 - MIL C 5541</p> <p>Pintura</p> <p><i>É executada utilizando tinta a pó de poliéster atóxica certificada QUALICOT e GSB em conformidade com as seguintes normativas:</i></p> <p>UNI 9983 - BS 6496 - AAMA 603-605</p> <p><i>Os tratamentos mencionados acima previnem a corrosão em ambientes marinhos na parte externa dos tubos, enquanto completamente recoberta pela pintura. A parte interna somente pré-tratada (com cromo) oferece também uma proteção aos tubos.</i></p>

ОГНЕСТОЙКОСТЬ

RESISTANCE TO FIRE
FEUERBESTÄNDIGKEIT
TENUE AU FEU
RESISTENCIA AL FUEGO
RESISTÊNCIA AO FOGO



<p>Предмет освидетельствования RU</p> <p>Классификация огнестойкости изделий и компонентов основана на результатах испытаний с воздействием пламени в соотв. с UNI EN 13501-1:2005.</p> <p>Описание изделия</p> <p>Труба алюминиевая окрашенная Серии 90000. Классификация определяется анализом теплоты сгорания лакокрасочного покрытия, в сочетании с результатами испытаний по методике UNI EN ISO 13823 алюминиевого листа той же толщины, с тем же лакокрасочным покрытием, что и труба.</p> <p>Результаты испытаний</p> <p>В ходе испытаний на огнестойкость испытуемого изделия оно было отнесено к Классу огнестойкости A2 - d1 - d0.</p>	<p>Subject GB</p> <p><i>Fire classification of construction products and building elements, based on the result of reaction to fire testing in accordance with UNI EN 13501-1:2005.</i></p> <p>Description of the product</p> <p><i>Painted aluminium pipe 90000 SERIES. Classification was determined by analysis of the paint's gross heat of combustion, coupled with test result as specified in UNI EN 13823 on equivalent flat sheets, having the same thickness of aluminium and paint as te pipe.</i></p> <p>Test Result</p> <p><i>The product under test has been awarded reaction to Fire Class A2 - d1 - d0, in accordance with test result obtained.</i></p>	<p>Gegenstand DE</p> <p><i>Die Feuerwiderstandsklassifizierung der Produkte und Komponenten, basiert auf den Testergebnissen zu Brandreaktionen, gemäss UNI EN 13501-1:2005.</i></p> <p>Produktbeschreibung</p> <p><i>Lackiertes Aluminium-Rohr der Serie 90000. Die Klassifizierung wurde erstellt durch die Analyse der Verbrennungswärme der Farbe, in Kombination mit den UNI EN ISO 13823 spezifizierten Testergebnissen zu flachen Aluminiumblechen in der gleichen Stärke und mit der gleichen Lackierung des Rohres.</i></p> <p>Testergebnis</p> <p><i>Das geprüfte Produkt wurde in der Feuerbeständigkeit als Produkt der Klasse A2 - d1 - d0 ausgezeichnet.</i></p>
<p>Sujet FR</p> <p><i>Classification des produits à la résistance au feu sur la base des résultats des tests selon la norme EN 13501-1:2005.</i></p> <p>Description des produits</p> <p><i>Tube en aluminium de la série 90000. La classification est déterminée par l'analyse de la chaleur de combustion des tubes en comparaison avec les résultats des essais spécifiés dans la norme UNI EN ISO 13823 sur des tôles d'aluminium peintes d'épaisseurs équivalentes.</i></p> <p>Résultats</p> <p><i>Le produit est attesté classe A2 - d1 - d0 en tenue au feu.</i></p>	<p>Asunto ES</p> <p><i>Certificación del fuego para productos y componentes basado en ensayos de reacción al fuego según UNI EN 13501-1:2005</i></p> <p>Descripción del producto</p> <p><i>Tubos Aluminio Infinity "90000 serie" revestidos. La clasificación mediante análisis de calor de combustión de la pintura, además de resultados específicos UNI EN 13823 sobre láminas planas con el mismo espesor y pintura.</i></p> <p>Resultados de la prueba</p> <p><i>El producto ha sido premiado con el grado de resistencia "FIRE CLASS A2 - d1 - d0", según pruebas.</i></p>	<p>Assunto PT</p> <p><i>Classificação de resistência ao fogo dos produtos e componentes, com base nos resultados dos testes de reação ao fogo segundo UNI EN 13501-1:2005.</i></p> <p>Descrição do produto</p> <p><i>Tubo de alumínio pintado Série 90000. A classificação é determinada pela análise do calor de combustão da tinta em combinação com os resultados dos testes especificados na UNI EN ISO 13823 feitos em lâminas chatas de alumínio com espessura e pintura equivalentes às utilizadas nos tubos.</i></p> <p>Resultado de Teste</p> <p><i>O produto submetido ao teste foi aprovado como produto de Classe A2 - d1 - d0 com relação a resistência ao fogo.</i></p>



Aignep si riserva il diritto di variare modelli e ingombri senza preavviso.
Aignep reserves the right to vary models and dimensions without notice.
Aignep behält sich das Recht vor, Daten ohne Ankündigung zu ändern.
Aignep se réserve le droit de modifier les données sans préavis.
Aignep se reserva el derecho de modificar modelos y dimensiones sin previo aviso.
Aignep reserva-se o direito de alterar os modelos e dimensões sem prévio aviso.

Aggiornamento - Updated - Mise à jour - Actualización - Atualização: 03/2019



AIGNEP SPA
Via Don G. Bazzoli - 34
25070 Bione (BS)
ITALY

T: +39 0365 896626
F: +39 0365 896561

aignep.it@aignep.com



AIGNEP IBERICA SA
Pol. Ind. el Tortuguier "Can Prat"
Naves 23 y 24 08691
Monistrol de Montserrat - Barcelona
SPAIN

T: +34 93 828 47 36
F: +34 93 828 44 32

aignep.es@aignep.com



**AIGNEP DO BRASIL COMERCIO DE
COMPONENTES PARA AUTOMAÇÃO LTDA**
Rua Campos Mello, 185
Vila Mathias - 11015-011 - Santos/SP
BRASIL

T: +55 13 2138 4049
F: +55 13 2138 4052

aignep.br@aignep.com



AIGNEP USA LLC
7121 Loblolly Pine Blvd
Fairview, TN 37062
U.S.A.

T: +1 615 771 6650
F: +1 615 771 0926

aignep.usa@aignep.com



AIGNEP AG
Industriestrasse 22A
2545 Selzach
SWITZERLAND

T: +41 32 342 09 09
F: +41 32 342 09 11

aignep.ch@aignep.com



AIGNEP FRANCE SARL
2, Avenue des Améthystes
44338 Nantes Cedex 3
FRANCE

T: +33 02 72 24 26 50
F: +33 02 72 24 26 51

aignep.fr@aignep.com



AIGNEP LATAM
SEDE:
Calle 15 N 27-78 Local 2
Sec. Paloquemao - 111411
Bogota
COLOMBIA

T: +57 1 37 52 50 1
T: +57 1 37 52 50 8

SUCURSAL:
Calle 6 SUR 52-80 Local 19
Cc. El Rodeo - 0520024 Medellin
COLOMBIA

T: +57 4 58 70 90 1

aignep.latam@aignep.com



**AIGNEP (Wuxi) FLUID
TECHNOLOGY CO., LT D.**
NO 8, Yanggong Road, Nanhu Main Road
Wuxi, Jiangsu.
CHINA

T: +86 0510 8544 1923
F: +86 0510 8540 0223

aignep.cn@aignep.com

www.aignep.com